



# OWNER'S OPERATING MANUAL

## Hardwire Uninterruptible Power Supply Models:

SG2K-1T-HW  
SG2K-2T-HW  
SG3K-1T-HW  
SG3K-2T-HW



Detailed SG Series product specifications are available in PDF format at [www.falconups.com](http://www.falconups.com)

---

FALCON Electric Inc., 5116 Azusa Canyon Rd., Irwindale, California 91706, (626) 962-7770, Fax 626-962-7720, Email: [sales@falconups.com](mailto:sales@falconups.com)

2006 Falcon® Electric Inc. All rights reserved.  
All other brand names and trademarks are the property of their respective owners.  
The information stated in this document is subject to change without notice. 2006-04-05  
Falcon®, Falcon® Electric and UPS Plus logos are registered trademarks of Falcon Electric Inc  
Rev. NR

# TABLE OF CONTENTS

<b>SG UPS Features.</b>	<b>1</b>
<b>SG Series Online UPS Block Diagram.</b>	<b>1</b>
<b>Important Safety Instructions (READ FIRST)</b>	<b>2</b>
<b>Chapter 1.</b>	
<b>SG Series UPS Overview</b>	<b>3</b>
<b>True Regenerative Online Design</b>	<b>3</b>
<b>Input Power Factor Correction</b>	<b>3</b>
<b>Microprocessor Control</b>	<b>3</b>
<b>SNMP/HTTP Remote Management</b>	<b>3</b>
<b>Dip Switch Settings Diagrams</b>	<b>5</b>
<b>Chapter 2.</b>	
<b>Installation Instructions</b>	<b>6</b>
<b>UPS Input and Output Requirements.</b>	<b>6</b>
<b>UPS Output Requirements.</b>	<b>7</b>
<b>UPS Startup</b>	<b>8</b>
<b>Extended Battery Bank Interconnection.</b>	<b>10</b>
<b>Extended Battery Bank Installation Procedure</b>	<b>10</b>
<b>Extended Battery Bank Selection Guide</b>	<b>11</b>
<b>Chapter 3.</b>	
<b>Operation</b>	<b>12</b>
<b>Front Panel Indicators &amp; Function Key Diagram</b>	<b>12</b>
<b>Front Panel Function Description</b>	<b>12</b>
<b>Audible Alarms</b>	<b>14</b>
<b>Category One Alarms</b>	<b>14</b>
<b>Category Two Alarms</b>	<b>14</b>
<b>Chapter 4.</b>	
<b>Rear Panel Details</b>	<b>15</b>
<b>SG2K-1T-HW &amp; SG3K-1T-HW Rear Panel.</b>	<b>15</b>
<b>SG2K-2T-HW &amp; SG3K-2T-HW Rear Panel .</b>	<b>15</b>
<b>Chapter 5.</b>	
<b>Communications Interfaces.</b>	<b>16</b>
<b>RS-232 Interface (DB-9)</b>	<b>16</b>
<b>Communications Option Slot</b>	<b>16</b>
<b>Contact Closure &amp; Opto Interface Options</b>	<b>17</b>
<b>Chapter 6.</b>	
<b>Maintenance &amp; Technical Support</b>	<b>20</b>
<b>Care &amp; Maintenance</b>	<b>20</b>
<b>Battery Life vs. Temperature</b>	<b>20</b>
<b>Battery Replacement</b>	<b>20</b>
<b>Storing the UPS and Batteries.</b>	<b>21</b>
<b>FCC Considerations</b>	<b>21</b>
<b>Technical Support &amp; RMA Procedure</b>	<b>22</b>
<b>Requesting Technical Information or Support.</b>	<b>22</b>
<b>FALCON Web Support.</b>	<b>22</b>
<b>Warranty</b>	<b>23</b>
<b>Specifications</b>	<b>24</b>

## SG SERIES UPS FEATURES

- Hardwire Input and Output Connection
- True Double Conversion On-Line Design
- Input Power Factor Correction
- Wide Input Voltage Window
- Pure Sinewave Output
- Precision Output Voltage Regulation
- Superior Brownout, Surge and Transient Protection
- Internal System Bypass
- Eliminates Generator Frequency & Voltage Drift
- Microprocessor Control & RS-232 Communications
- UPSILON® Monitoring & Shutdown Software
- Optional Frequency Conversion
- Optional Extended Battery Packs & Chargers
- Optional External Maintenance Bypass Switch
- Optional Internal SNMP/HTTP Interface Card
- Two-Year Warranty

## SG SERIES ON-LINE UPS SYSTEM BLOCK DIAGRAM

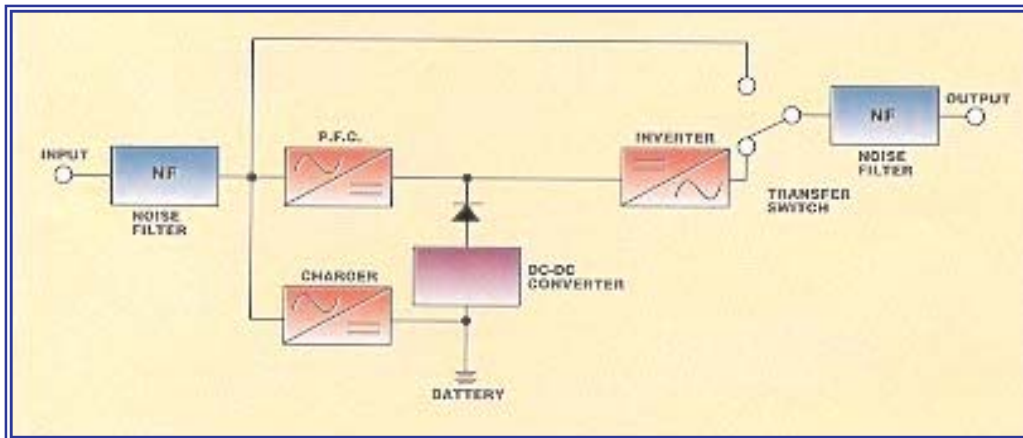

# IMPORTANT SAFETY INSTRUCTIONS

## SAVE THESE INSTRUCTIONS

This manual contains important instructions which must be followed during the installation, operation and maintenance of this UPS and its batteries. Please read all instructions before operating this equipment and save this manual for future reference.

### CAUTION

All of the models presented herein are designed for installation and use in a protected, temperature controlled environment, free of contamination.

### CAUTION

This UPS utilizes voltage that may be hazardous. Do not attempt to disassemble. This unit contains no user replaceable parts. **Refer all servicing to Falcon Electric, Inc.**

### CAUTION

**THIS UPS IS NOT INTENDED TO BE USED IN CONJUNCTION WITH LIFE SUPPORT OR OPERATING ROOM EQUIPMENT.**

### CAUTION

Always unplug this UPS and remove the UPS battery fuse prior to cleaning and never apply liquid or spray detergent on the UPS.

### CAUTION

**Never attempt to service batteries.** High voltage exists within the unit, which could cause electrical shock. Servicing of batteries should be performed or supervised by personnel knowledgeable of batteries and the required precautions. Keep unauthorized personnel away from batteries. When replacing the UPS batteries, use the same number and type of batteries.

### IMPORTANT

Allow at least 24 hours, after the UPS is first installed and turned on, to fully charge the internal battery and assure the maximum backup time is available.

### DO NOT

**DO NOT** plug this UPS into its own output as this may damage the UPS. **NEVER CONNECT** equipment that could overload the UPS or demand half-wave rectification from the UPS, for example: electric drills, vacuum cleaners or hair dryers. Never connect surge protected plug strips to the UPS output.

### CAUTION

**DO NOT** remove or unplug the input cord when the UPS is turned on. This removes the safety ground from the UPS and the equipment connected to the UPS.

### CAUTION

**This UPS contains its own energy source (batteries). The output receptacles may carry live voltage even when the UPS is not connected to an AC source.**

### IMPORTANT

**Should any SG Series UPS units be stored for more than two weeks, it is mandatory that the battery fuse be removed prior to storage or battery damage will result.**

# CHAPTER 1

## SG Series UPS - Overview

### General - Common for all models

1. Verify the following is included in the UPS shipping carton:  
(1) UPS, (1) Software Diskette(s) & Manual, (1) Owners Manual & (1) UPS/Computer Cable.
2. Verify the UPS unit is configured for the proper input/output voltage and frequency. This information is stated on the nameplate label located on the rear or the side panel of the unit. If any special input plug and output receptacle configurations were specified at the time of order, verify for proper configuration.
3. Set the output voltage and green mode switches located on the UPS rear panel for the nominal UPS output voltage desired. **See the switch setting tables located on page 5.**

In most cases the nominal UPS output voltage should be set to match the incoming utility voltage. This will assure a close matching voltage in the event the UPS is placed on bypass. **NOTE: Disregard the "ON" marking on the side of the actual dip switch housing; use the tables in this manual or the silkscreen on the UPS rear panel only.**

**Dip switch 3 "enables" or "disables" the "Green Mode" function.** The UPS is shipped from the factory with the switch set in the "disabled" position (up). If SW3 is switched down or to the "enabled" position, the Green Mode function is activated. When the load connected to the output of the UPS drops to under 10% of the full rated UPS output for 30 seconds, the UPS is automatically placed into bypass and the inverter is turned off. **NO BATTERY BACKUP IS PROVIDED AFTER THE GREEN MODE HAS ACTIVATED.**

Dip switch settings must be made while the UPS is turned off. Any changes made while the UPS is turned on will not take effect until the UPS is turn off and back on again since the switch settings are read by the microprocessor only during initial UPS power up.

4. To prevent accelerated battery discharge during shipment, this UPS was shipped with the battery circuit breaker turned off. **TURN THE BATTERY DISCONNECT CIRCUIT BREAKER ON PRIOR TO TURNING ON THE UPS INPUT CIRCUIT BREAKER.**

**NEVER TURN THE BATTERY CIRCUIT BREAKER OFF WHILE THE UPS AC CIRCUIT BREAKER IS TURNED ON AND OPERATING FROM THE UTILITY VOLTAGE, OR UPS DAMAGE MAY RESULT. UPS MUST BE COMPLETELY SHUT DOWN PRIOR TO DISABLING THE INTERNAL BATTERY SUPPLY.**

In the event this UPS is to be turned off or stored for more than two weeks, the battery circuit breaker must be turned to the off position to prevent battery discharge. If placed in long-term storage, every four months the UPS must be plugged in and turned on for 24 hours to allow the batteries to recharge and prevent battery damage. Failure to follow these procedures will invalidate your warranty.

5. Select a suitable location for the UPS.

**VERIFY THE FLOOR OR SURFACE SUPPORTING THE UPS WILL SUPPORT THE WEIGHT OF THE UPS AND ANY OPTIONAL EXTENDED BATTERY BANKS.**

SG2K-2T-HW & SG2K-2T-HW UPS MODELS = 68.4 lbs. (31 kg)

SG3K-2T-HW & SG3K-2-HW UPS MODELS = 81.4 lbs. (37 kg)

6. If unattended computer shutdown and monitoring are desired, connect the green UPS/Computer cable to the DB-9 connector located on the UPS rear panel. Then install the shutdown and monitoring software provided with the UPS. For your reference, UNIX shutdown and monitoring software is available from Falcon Electric at an additional cost.
7. Verify the location selected has adequate ventilation to allow for the proper cooling of the UPS.

**DO NOT BLOCK UPS FANS OR AIR VENTS. THE UPS MUST NOT BE INSTALLED IN AN ENCLOSED AREA.**

**VIEW OF OUTPUT VOLTAGE & GREEN MODE SELECT SWITCHES  
(LOCATED ON THE UPS REAR PANEL)**

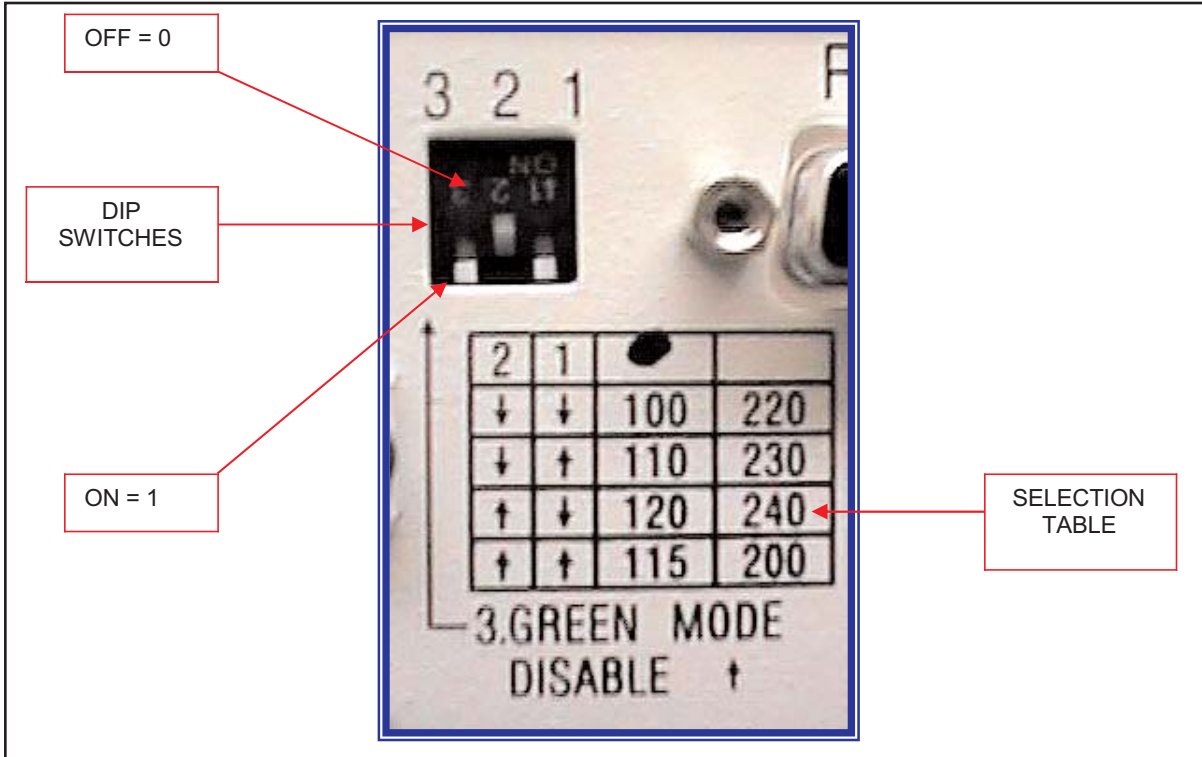

**SWITCH SETTINGS FOR ALL MODELS**

SW2	SW1	OUTPUT VOLTAGE 1 (All models)	OUTPUT VOLTAGE 2 (-TX & -TXC models only)
Down	Down	208 Vac	115 Vac
Down	Up	220 Vac (default)	120 Vac
Up	Down	230 Vac	125 Vac
Up	Up	240 Vac	130 Vac

**GREEN MODE SWITCH SETTINGS FOR ALL MODELS**

SW3	FUNCTION
Down	GREEN MODE ON
Up	GREEN MODE OFF

# CHAPTER 2

## Installation Instructions For Hardwire Models

### 1.0 UPS Input & Output Requirements.

**Note: All SG Series hardwire UPS models must be installed by a licensed electrician, in accordance with the National Electrical Code (NEC) ANSI/NFPA70 and all local regulations. It is further required that the input of SG Series hardwire UPS be wired to a building service panel incorporating a dedicated “branch rated” circuit breaker of the proper rating.**

<u>MODEL</u>	<u>REQUIRED BRANCH RATED CIRCUIT BREAKER</u>
<u>SG2K-1T-HW</u> : - 120Vac, 50/60Hz, 14.2A, 1 phase, 2 wire plus ground	20A
<u>SG2K-2T-HW</u> - 208-240Vac, 50/60Hz, 7.4A, 1 phase, 2 wire plus ground	15A
<u>SG3K-1T-HW</u> - 120Vac, 50/60Hz, 21.4A, 1 phase, 2 wire plus ground	30A
<u>SG3K-2T-HW</u> - 208-240Vac, 50/60Hz, 11.2A, 1 phase, 2 wire plus ground	20A

WIRE GAUGE CHART			
MODEL	AC INPUT -1 = 120 Vac -2 = 208-240 Vac	AC OUTPUT(S)	
		120 Vac	208 -240 Vac
SG2K-1T-HW	10 Awg. 600V 75°C CU	10 Awg. 600V 75°C CU	N/A
SG2K-2T-HW	12 Awg. 600V 75°C CU	N/A	12 Awg. 600V 75°C CU
SG3K-1T-HW	10 Awg. 600V 75°C CU	10 Awg. 600V 75°C CU	
SG3K-2T-HW	12 Awg. 600V 75°C CU		12 Awg. 600V 75°C CU

**ONLY USE WIRE WITH SOLID COPPER CONDUCTORS FOR ALL INPUT/OUTPUT/BATTERY WIRING**

SCREW TORQUE SPECIFICATIONS FOR INPUT/OUTPUT WIRING BLOCK UPS	
Wire Gauge	Torque (inch pounds)
18 - 10 Awg.	20
8-6 Awg	25 - 30

### CAUTION

**To reduce the risk of fire, connect only to a circuit providing over-current protection incorporating the specified "branch rated" over-current protection device in accordance with the National Electrical Code, ANSI/NFPA 70.**



## 1.1 UPS Output Requirements

**Note: The outputs of the SG2K-2T-HW & SG3K-2T-HW hardwire models are not configured for 240/120Vac split-phase operation. Should a 240/120Vac split-phase output configuration be required, please contact the factory.**

<u>MODEL</u>	<u>RECOMMENDED BRANCH RATED OUTPUT CIRCUIT BREAKER</u>
<u>SG2K-1T-HW:</u> Output 1: 100, 110, 115 or 120Vac selectable, 1 phase, 2 wire plus ground	20A
<u>SG2K-2T-HW</u> Output 1: 200, 220, 230 or 240Vac selectable, 1 phase, 2 wire plus ground	15A
<u>SG3K-1T-HW</u> Output 1: 100, 110, 115 or 120Vac selectable, 1 phase, 2 wire plus ground	30A
<u>SG2K-2T-HW</u> Output 1: 200, 220, 230 or 240Vac selectable, 1 phase, 2 wire plus ground	20A



### Terminal Wiring Designations

- |                              |                             |
|------------------------------|-----------------------------|
| 1 - Utility L1               | 4. UPS Output L1            |
| 2 - Utility L2 or Neutral    | 5. UPS Output L2 or Neutral |
| 3 - Input and Output Grounds |                             |

### View of the Input/Output Hardwire Terminal Block

This terminal block is located on the UPS rear panel and shown with the access cover plates removed.

**Use only the lower terminals and wire securing screws when making wiring connections to the UPS.**

### DO NOT USE THE UPPER TERMINAL CONNECTIONS

Refer to the Wire Gauge Table on Page 7 for recommended wire sizes.

Refer to the Torque Specification Table on Page 7 and tighten all 20 screws as specified.

Refer to Pages 9-10 for the terminal wiring designations for your specific SG UPS model.

## 2.0 UPS STARTUP

1. Verify the following is included in the UPS shipping carton:  
(1) UPS, (1) Software Diskette(s) & Manual, (1) Owners Manual & (1) UPS/Computer Cable.
2. Verify the UPS unit is configured for the proper input/output voltage and frequency. This information is stated on the nameplate label located on the rear or the side panel of the unit. If any special input plug and output receptacle configurations were specified at the time of order, verify for proper configuration.
3. Note: If you have requested the UPS input and output voltage be factory configured, disregard the following switch setting instructions.

Set the Dip switches located on the UPS rear panel for the nominal UPS output voltage desired. **See the dip switch setting tables located on page 6.**

In most cases the nominal UPS output voltage should be set to match the incoming utility voltage. This will assure a close matching voltage in the event the UPS is placed on bypass. **NOTE: Disregard the "ON" marking on the side of the actual dip switch housing; use the tables in this manual or the silkscreen on the UPS rear panel only.**

**Dip switch 3 "enables" or "disables" the "Green Mode" function.** The UPS is shipped from the factory with the switch set in the "disabled" position (up). If SW3 is switched down or to the "enabled" position, the Green Mode function is activated. When the load connected to the output of the UPS drops to under 10% of the full rated UPS output for 30 seconds, the UPS is automatically placed into bypass and the inverter is turned off. **NO BATTERY BACKUP IS PROVIDED AFTER THE GREEN MODE HAS ACTIVATED.**

Dip switch settings must be made while the UPS is turned off. Any changes made while the UPS is turned on will not take effect until the UPS is turn off and back on again since the switch settings are read by the microprocessor only during initial UPS power up.

4. To prevent accelerated battery discharge during shipment, the UPS has been shipped with the battery fuse removed. **DEPRESS THE PRECHARGE BUTTON FOR ONE SECOND AND IMMEDIATELY INSTALL THE BATTERY FUSE PRIOR TO TURNING ON THE UPS INPUT CIRCUIT BREAKER OR PLUGGING IN THE UPS.**

### CAUTION

**NEVER REMOVE THE BATTERY FUSE WHILE THE UPS AC CIRCUIT BREAKER IS TURNED ON AND OPERATING FROM THE UTILITY VOLTAGE OR UPS DAMAGE MAY RESULT. UPS SHOULD BE COMPLETELY SHUT DOWN PRIOR TO DISABLING THE INTERNAL BATTERY SUPPLY.**

### CAUTION

In the event this UPS is to be turned off or stored for more than two weeks, the battery fuse should be removed to prevent excessive battery discharge. If placed in long-term storage, every four months the UPS must be plugged in and turned on for 24 hours to allow the batteries to recharge and prevent battery damage. Failure to follow these procedures may invalidate your warranty.

5. Select a suitable location for the UPS near enough to the computer or equipment to be protected. Connect the power cord(s) for the equipment to be protected to the UPS output receptacles.  
**VERIFY THE TABLE OR SURFACE SUPPORTING THE UPS WILL SUPPORT THE WEIGHT OF THE UPS AND ANY OPTIONAL EXTENDED BATTERY BANKS.**  
2KVA- 3KVA UPS MODELS = 150.0 lbs, (68kg)
6. If extended battery banks are to be connected to the UPS, please refer to page 8 for further instructions.
7. If unattended computer shutdown and monitoring are desired, connect the green UPS/Computer cable to the DB-9 connector located on the UPS rear panel. Then install the shutdown and monitoring software provided with the UPS. For your reference, UNIX shutdown and monitoring software is available from Falcon Electric at an additional cost.
8. Verify the location selected has adequate ventilation to allow for the proper cooling of the UPS.  
**DO NOT BLOCK UPS FANS OR AIR VENTS. THE UPS MUST NOT BE INSTALLED IN AN ENCLOSED AREA.**
9. Turn the input circuit breaker located on the UPS rear panel to the "on" position. The internal UPS fan and front panel "line" indicator should turn on, followed by the "bypass" LED, and after several seconds, the "inverter" LED.
10. Turn on the connected equipment and verify the UPS does not go into overload by observing the front panel load indicator LEDs.
11. The UPS, optional external battery bank(s) and additional chargers should be installed and turned on for 24 hours to charge the batteries. During this initial 24 hour charging period, battery backup time may be substantially reduced.

### **IMPORTANT**

#### **TO TURN OFF THE UPS.**

1. **SWITCH OFF THE INPUT CIRCUIT BREAKER LOCATED ON THE UPS REAR PANEL.**
2. **PRESS THE ON/OFF BUTTON LOCATED ON THE UPS FRONT PANEL UNTIL THE UPS BEEPS.**
3. **THE UPS WILL CONTINUE TO OPERATE FOR ABOUT 30 SECONDS AND THEN SHUTDOWN.**

**DO NOT PRESS THE ON/OFF BUTTON OR TURN THE CIRCUIT BREAKER ON AGAIN DURING THE SHUTDOWN PROCESS OR THE UPS WILL GO TO AN ALARM CONDITION, WARNING THAT THE UPS WAS NOT SHUTDOWN PROPERLY. SHOULD THIS OCCUR, TURN OFF THE INPUT CIRCUIT BREAKER AGAIN AND WAIT UNTIL THE UPS SHUTS DOWN.**

**TYPICAL EXTENDED BATTERY BANK & UPS INTERCONNECTION**  
(Mini-tower models shown; same applies for floor standing banks)

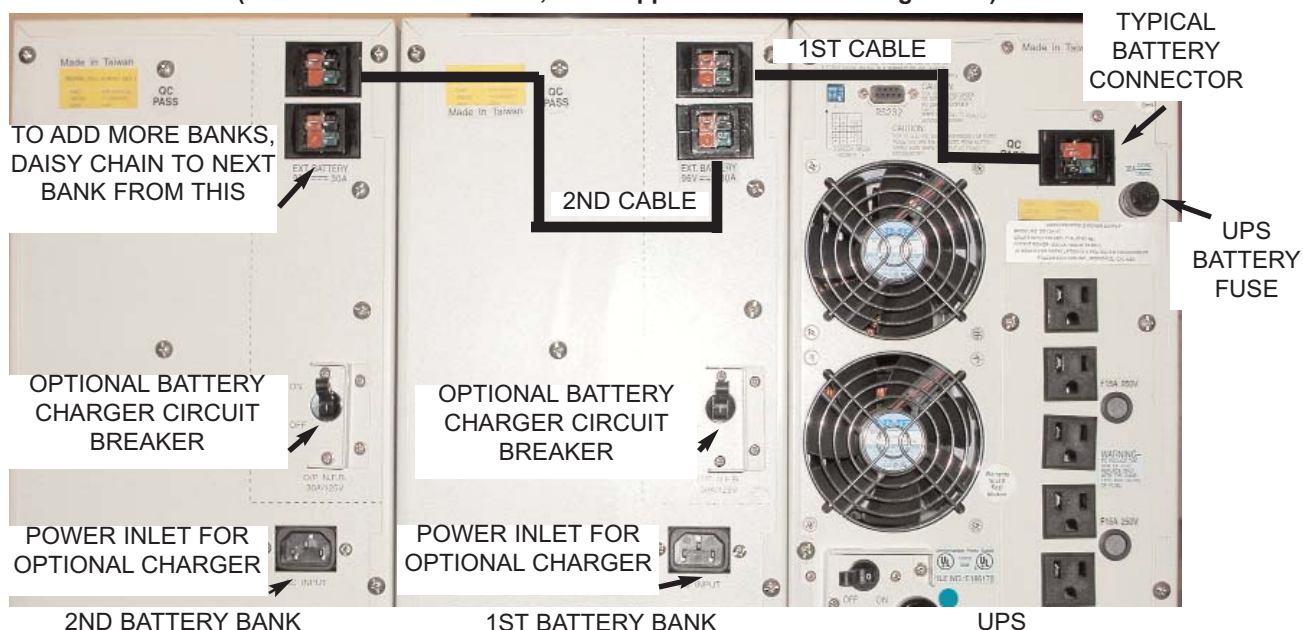

**INSTALLATION PROCEDURE FOR EXTENDED BATTERY BANKS**

1. Remove the battery fuse located on the UPS rear panel. See illustration above.
2. Locate the battery interconnect cable(s).
3. Connect one end of the battery interconnect cable to the the UPS battery connector. Connect the other end of the cable to the top battery connector on the first battery bank. See illustration above.
4. If a second battery bank is to be connected, connect one end of the second battery interconnect cable to the bottom battery connector on the first battery bank and connect the other end of the cable to the top battery connector of the second battery bank. (See illustration above.)
5. Follow the instructions in the proceeding step for additional battery banks.
6. Reinstall the battery fuse.
7. For all battery banks that have the battery charger option installed from the factory, perform the following:
  - a. Verify the battery charger circuit breaker is in the off (down) position.
  - b. On the battery bank nameplate label located on the rear panel, verify the battery charger input voltage matches your utility source (120Vac or 230Vac).
  - c. Connect the input line cord(s) to the battery bank(s) power inlet.
  - d. Plug the other end of the power cord into a utility receptacle.
  - e. Turn on the battery charger circuit breaker(s) (up).
  - f. The batteries in the external battery banks are now being charged.

**NOTE:** Internal battery bank chargers do not charge the UPS batteries.

**NOTE:** When the battery banks and UPS need to be shutdown for more than two weeks, turn off the battery charger circuit breaker, disconnect the interconnecting cables and remove the battery fuse from the UPS battery or damage may occur.

8. RETURN TO PAGE 5, Paragraph 8 FOR FURTHER INSTALLATION INSTRUCTIONS.

## SG 2-3kVA TOWER EXTENDED BATTERY BANK SELECTION GUIDE

### FOR 2KVA -HW MODELS

<b>BATTERY OPTION MODELS W/O Charger</b>	SGB2S7-2K3	SGB2S7-2K3	SGB5S7-2K6	SGB2S7-2K3	SGB5S7-2K6	SGB5S7-2K6
<b>BATTERIES</b>	12 Pieces of 12V, 7AH	24 Pieces of 12V, 7AH	30 Pieces of 12V, 7AH	36 Pieces of 12V, 7AH	60 Pieces of 12V, 7AH	90 Pieces of 12V, 7AH
<b>BATTERIES IN UPS</b>	6 each of 12V, 7AH					
<b># of CASES</b> Inches (mm)	1 Mini-Tower 13.8 x 7.6 x 18.9 (350 x 193 x 480)	2 Mini-Towers 13.8 x 7.6 x 18.9 (350 x 193 x 480)	1 Floor Standing 32.1 x 10.2 x 21.8 (814 x 193 x 554)	3 Mini-Towers 13.8 x 7.6 x 18.9 (350 x 193 x 480)	2 Floor Standing 32.1 x 10.2 x 21.8 (814 x 193 x 554)	3 Floor Standing 32.1 x 10.2 x 21.8 (814 x 193 x 554)
<b>RUN TIME @ 300W</b>	170 Min.	310 Min.	390 Min.	470 Min.	760 Min.	1200 Min.
<b>RUN TIME @ 500W</b>	95 Min.	180 Min.	225 Min.	260 Min.	465 Min.	690 Min.
<b>RUN TIME @ 700W</b>	63 Min.	120 Min.	155 Min.	185 Min.	320 Min.	490 Min.
<b>RUN TIME @ 1000W</b>	39 Min.	79 Min.	100 Min.	120 Min.	215 Min.	330 Min.
<b>RUN TIME @ 1400W</b>	24 Min.	51 Min.	64 Min.	80 Min.	140 Min.	225 Min.
<b>CHARGER OPTION INFORMATION</b>						
<b>BATTERY OPTION MODELS With 120Vac Charger</b>	SGB2S7-2K3-1	SGB2S7-2K3-1	SGB5S7-2K6-1	SGB2S7-2K3-1	SGB5S7-2K6-1	SGB5S7-2K6-1
<b>BATTERY OPTION MODELS With 208-240Vac Charger</b>	SGB2S7-2K3-2	SGB2S7-2K3-2	SGB5S7-2K6-2	SGB2S7-2K3-2	SGB5S7-2K6-2	SGB5S7-2K6-2
<b>CHARGER OUTPUT</b>	82.5Vdc @ 4A	82.5Vdc @ 4A	82.5Vdc @ 4A	82.5Vdc @ 4A	82.5Vdc @ 4A	82.5Vdc @ 4A
<b>#. OF CHARGERS</b>	1	1	1	1	2	3

### FOR 3KVA -HW MODELS

<b>BATTERY OPTION MODELS W/O Charger</b>	SGB2S7-3K3	SGB2S7-3K3	SGB5S7-3K6	SGB2S7-3K3	SGB5S7-3K6	SGB5S7-3K6
<b>BATTERIES</b>	16 Pieces 12V,7AH	32 Pieces 12V, 7AH	40 Pieces 12V, 7AH	48 Pieces 12V, 7AH	80 Pieces 12V, 7AH	160 Pieces 12V, 7AH
<b>BATTERIES IN UPS</b>	8 each of 12V, 7AH					
<b># of CASES</b> H x W x D Inches (mm)	1 Mini-Tower 13.8 x 7.6 x 18.9 (350 x 193 x 480)	2 mini-Towers 13.8 x 7.6 x 18.9 (350 x 193 x 480)	1 Floor Standing 32.1 x 10.2 x 21.8 (814 x 259 x 554)	3 Mini-Towers 13.8 x 7.6 x 18.9 (350 x 193 x 480)	2 Floor Standing 32.1 x 10.2 x 21.8 (814 x 259 x 554)	4 Floor Standing 32.1 x 10.2 x 21.8 (814 x 259 x 554)
<b>RUN TIME @ 500W</b>	135 Min.	260 Min.	310 Min.	380 Min.	640 Min.	1350 Min.
<b>RUN TIME @ 1000W</b>	59 Min.	115 Min.	140 Min.	170 Min.	300 Min.	620 Min.
<b>RUN TIME @ 1500W</b>	33 Min.	68 Min.	84 Min.	105 Min.	190 Min.	400 Min.
<b>RUN TIME @ 2100W</b>	20.5 Min.	43 Min.	57 Min.	69 Min.	125 Min.	270 Min.
<b>CHARGER OPTION INFORMATION</b>						
<b>BATTERY OPTION MODELS With 120Vac Charger</b>	SGB2S7-3K3-1	SGB2S7-3K3-1	SGB5S7-3K6-1	SGB2S7-3K3-1	SGB5S7-3K6-1	SGB5S7-3K6-1
<b>BATTERY OPTION MODELS With 208-240Vac Charger</b>	SGB2S7-3K3-2	SGB2S7-3K3-2	SGB5S7-3K6-2	SGB2S7-3K3-2	SGB5S7-3K6-2	SGB5S7-3K6-2
<b>CHARGER OUTPUT</b>	110Vdc @4.5A	110Vdc @4.5A	110Vdc @4.5A	110Vdc @4.5A	110Vdc @4.5A	110Vdc @4.5A
<b># OF CHARGERS</b>	1	1	1	1	2	4

**NOTE:** The backup times stated are for reference only. Backup time may vary due to the type of load, battery age or condition, environmental conditions, etc.

# CHAPTER 3

## OPERATION

UPS FRONT PANEL INDICATOR AND FUNCTION KEYS

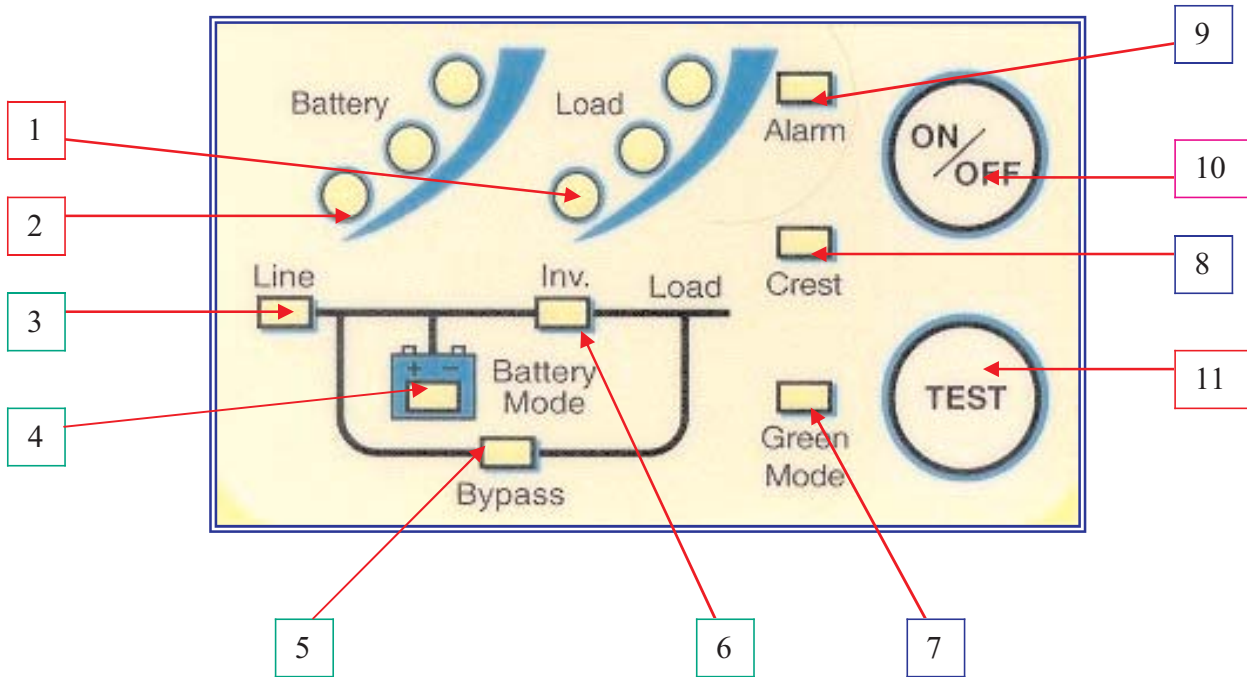

### 1. LOAD LEVEL INDICATOR LEDS

- \*The first or bottom LED is lit when the output load is greater than 25% of the rated output of the UPS.
- \*The second LED is lit when the output load is greater than 50% of the rated output of the UPS.
- \*The third LED is lit when the output load is greater than 75% of the rated output of the UPS.

### 2. BATTERY LEVEL INDICATOR LEDS

- \*The third or top LED is lit when the battery is fully charged.
- \*The Second LED is let when the battery level is above the low battery warning Level.
- \*The first LED is lit when the battery level is above the battery cutoff voltage.

### 3. LINE / SITE WIRING FAULT INDICATOR LED

For models configured for standard 120 volt domestic usage, this LED is lit to a steady on state when Utility voltage is present. However, should the LED flash on and off, it is an indication that the HOT and NEUTRAL wires are reversed some where in the building wiring. Typically at the wall outlet. It is normal for this LED to flash with 208 and 240 volt domestic models as these voltages are normally LINE to LINE, without a neutral.

### 4. BATTERY MODE INDICATOR LED

This LED is lit when the unit is operating from battery.

5. **BYPASS INDICATOR LED**

When this LED is lit the UPS bypass is active. Should the Alarm LED be lit at the same time, the UPS detected an internal failure and the UPS must be serviced.

6. **INVERTER INDICATOR LED**

When this LED is lit, the UPS inverter is operating and powering the connected load.

7. **GREEN MODE LED INDICATOR**

This LED is lit when the connected output load of the UPS drops to under 10% of the full rated output of the UPS, providing SW3 is in the "down" position (Green Mode Enabled) as shown on page 7. The UPS is automatically set to bypass mode and the inverter is turned off, reducing the power requirement. **NO BATTERY BACKUP IS PROVIDED IN THIS MODE.** (The UPS is shipped from the factory with SW3 in the "up" or disabled position.)

8. **OVER CREST INDICATOR LED**

This LED lights when the connected load getting close to the peak current rating of the UPS.

9. **ALARM INDICATOR LED**

This LED is lit during the following conditions:

- a. The inverter voltage is too high or low.
- b. UPS over-temperature condition.
- c. The battery voltage is too high.
- d. The internal DC Bus has an under or over voltage condition.
- e. The internal microprocessor or memory failure.

10. **ON / OFF BUTTON**

**The following describes the different modes of operation for this button:**

- a. Depressing this button when the UPS is off, and the utility voltage is not present, or with the UPS input circuit breaker in the off position, will cause the UPS to DC start and run on internal battery until the ON/OFF button is depressed again.
- b. Pressing this button while the UPS is on, and utility is present, will place the UPS into bypass mode.
- c. Pressing this button when with the UPS input circuit breaker off, or when the utility voltage is not present, will turn off the UPS.

**TO TURN UPS ON:** CONNECT THE UPS TO UTILITY POWER AND TURN ON THE MAIN CIRCUIT BREAKER LOCATED ON THE REAR PANEL. DO NOT PRESS THE "ON" BUTTON LOCATED ON THE FRONT PANEL OR THE UPS WILL BE PLACED INTO BYPASS MODE.

**TO TURN UPS OFF:** TURN OFF THE MAIN CIRCUIT BREAKER LOCATED ON THE REAR PANEL AND DEPRESS THE "ON/OFF" BUTTON UNTIL THE UPS BEEPS AND WAIT FOR THE UPS TO SHUTDOWN AND TURN OFF (ABOUT 30 SECONDS).

11. **TEST BUTTON**

The following describes the different modes of operation for this button:

- a. Pressing the Test button while in Green Mode will disable Green Mode.
- b. Pressing the Test button while utility is present will put the UPS through a self test diagnostic.
- c. Pressing the Test button while in battery mode will turn the battery Audible alarm off. Depressing it again will turn the Audible alarm back on.

## AUDIBLE ALARMS

Audible alarm signals are divided into two different levels of alarm status. Category one alarms represent normal or correctable operational alarms. Category two alarms are sounded in the event of abnormal operation.

### 1. Category one alarms:

- a. Two short beeps followed by three short beeps.  
Notifies the user that the SG UPS is configured with the optional battery pack and is in BATTERY MODE.  
**-- --- = SG UPS IS IN BATTERY MODE**
- b. A continuous short beep.  
The SG UPS is operating from battery and is in a LOW BATTERY operation.  
**----- = SG UPS IS IN A LOW BATTERY CONDITION**
- c. One long beep prior to a short beep.  
The SG UPS is in an OVER LOADED, OVER CREST CONDITION. Remove some load from the UPS output to correct this condition.  
**--- = SG UPS IS IN OVERLOAD OR OVER CREST**
- d. One short beep is sounded when either the ON/OFF or TEST buttons are pressed and held. This notifies the user the associated actions have been initiated by the UPS.  
**- = WHEN SG UPS FRONT PANEL ON, OFF AND TEST BUTTONS ARE DEPRESSED.**
- e. One short beep is sounded when the SELF-TEST button has been pressed and held. This notifies the self test has been started.

**- = WHEN SG UPS FRONT PANEL TEST BUTTON DEPRESSED.**

### 2. Category two alarms:

- a. Three short beeps indicate the SG UPS output voltage is out of proper operating range.  
**--- = SG UPS OUTPUT VOLTAGE IS OUT OF PROPER RANGE.**
- b. Four short beeps indicate the SG UPS output frequency is out of proper operating range. The UPS must be repaired.  
**---- = SG UPS OUTPUT FREQUENCY IS OUT OF PROPER RANGE.**
- c. Five short beeps indicate the SG UPS is in an over-temperature condition. Check for proper UPS cooling fan operation or blockage.  
**----- = SG UPS INTERNAL TEMPERATURE IS TOO HIGH.**
- d. Should the internal POWER UP SELF-TEST fail, the SG UPS will sound the following alarms denoting the failure mode:
  - \* A continuous rapid beeping for about 5 seconds, then the SG UPS shuts down - The UPS output voltage is out of range.  
**----- = UPS OUTPUT VOLTAGE IS OF RANGE.**
  - \* A continuous rapid beeping for about 2 seconds and the SG UPS shuts down - The SG UPS performed a DC start, but there is no output frequency set in the UPS memory. Plug the UPS into your local utility power and turn the UPS on to set it for your local utility power frequency.  
**----- = The SG UPS performed a DC start, but there is no output frequency set in memory. Connect the UPS to your local utility power and turn on the UPS. Your local utility frequency is now set into the UPS memory. The next time the UPS is DC Started, its output frequency will be set automatically.**



**SG2K-1T-HW & SG3K-1T-HW  
Typical Rear Panel Overview**

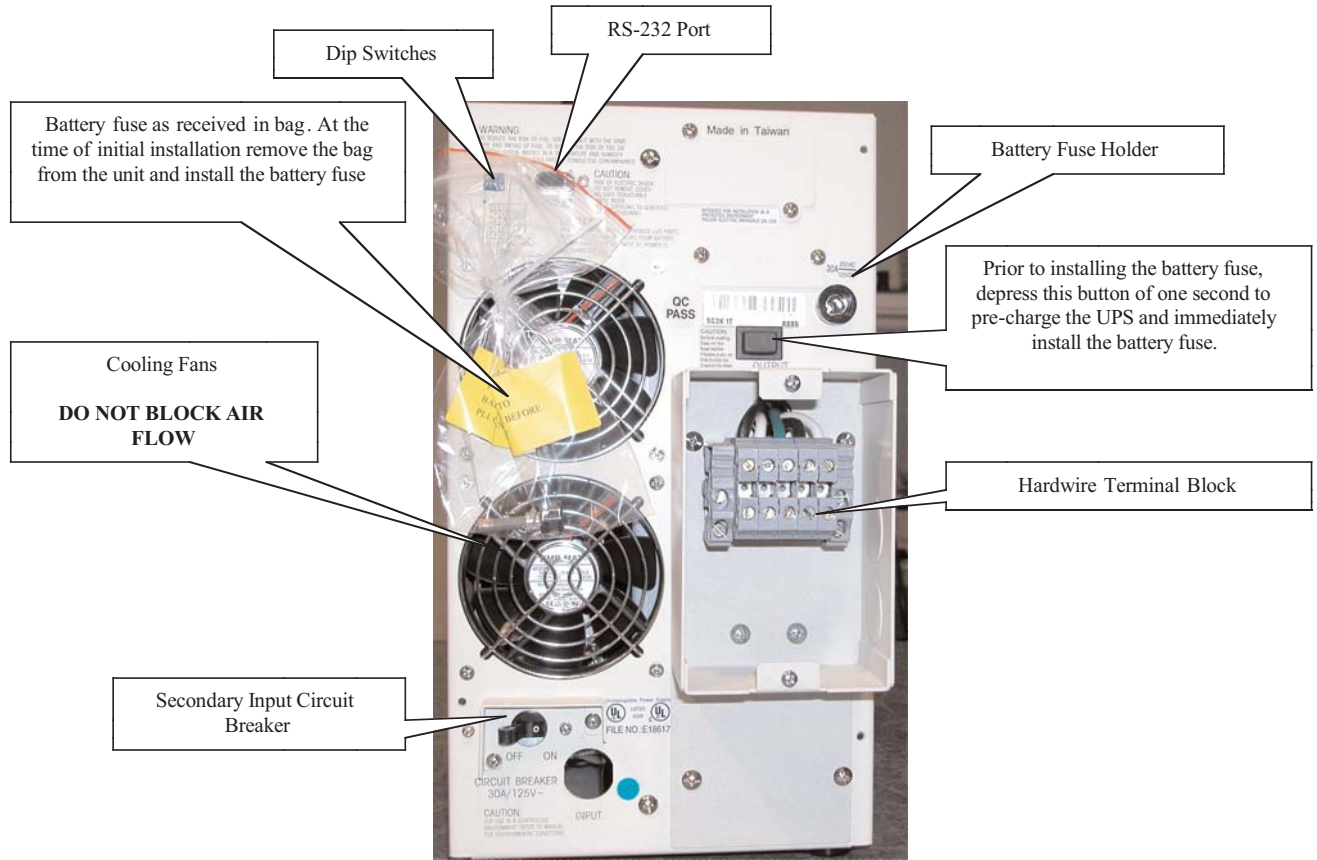

**SG2K-2T-HW & SG3K-2T-HW  
Typical Rear Panel Overview**

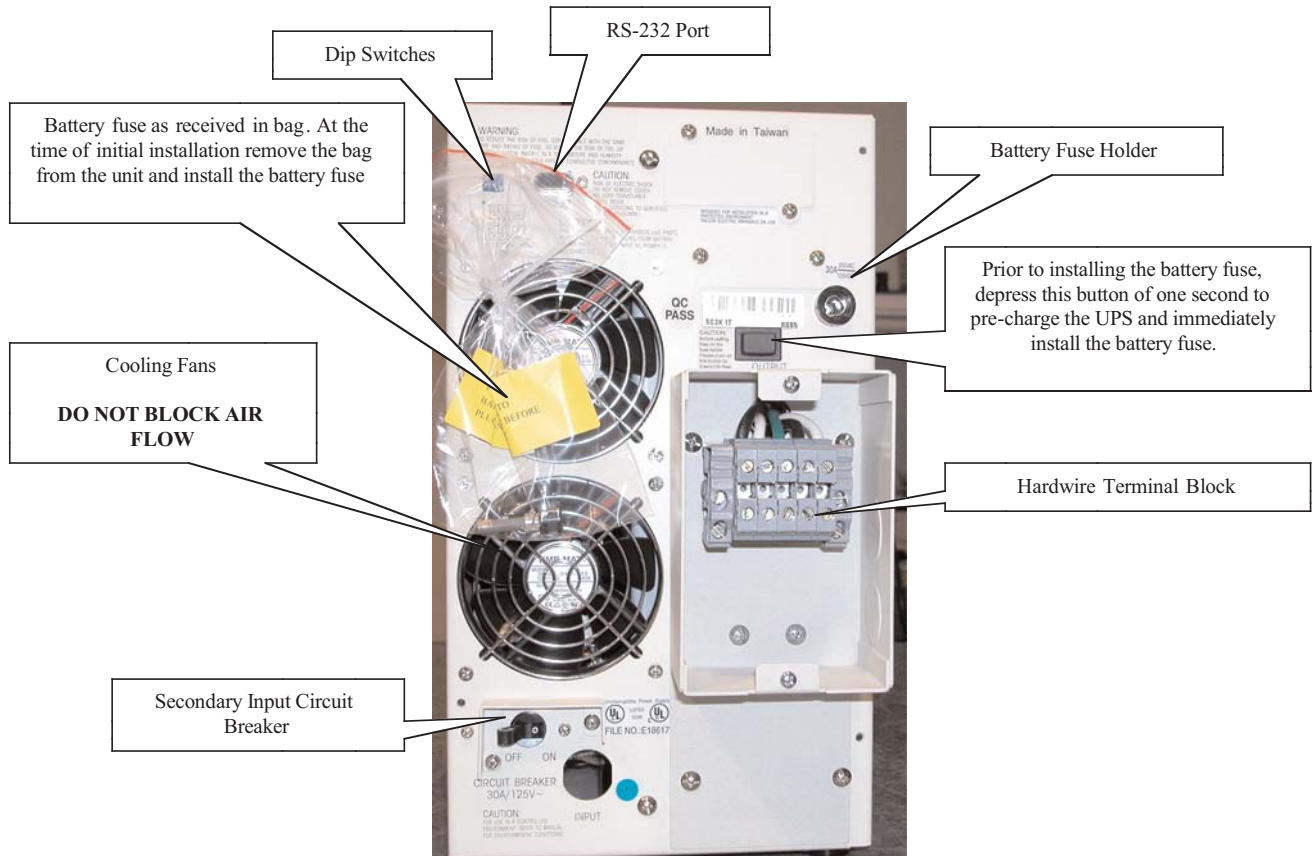

# CHAPTER 5

## COMMUNICATIONS INTERFACES

### RS-232 INTERFACE

#### Location:

The RS-232 interface is standard on all SG series UPS models. The port is located on the UPS rear panel, via a DB-9 female connector.

#### Supported Protocols

UPSILON 2000 & SEC Smart Mon

BAUD RATE ----- 2400bps  
DATA LENGTH---- 8 bits  
STOP BIT----- 1 bit  
PARITY----- None

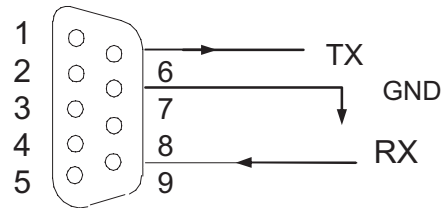

DB-9 Connector Pin Assignment

Pin #	Function explanation	I/O
9	RS 232 Rx	INPUT
6	RS 232 Tx	OUTPUT
7	Ground	

#### CAUTION

When making a connection between a computer and the UPS RS-232 port, always use the green cable supplied with the UPS.

#### CAUTION

There are communications options that WILL DISABLE the RS-232 port and render it inoperable. The options are as follows:

- Internal SNMP/HTTP agent option installed into the UPS communications option slot.

The following options WILL NOT affect the operation of the RS-232 port:

- Falcon Opto Coupler based signal interface board installed to the communications option slot.
- Any Falcon relay based, dry contact signal interface board installed into the communications option slot.

#### CAUTION

DB-9 Signals are not isolated and intended for connection to like RS-232 interfaces. **DO NOT APPLY ANY OTHER VOLTAGES TO THESE PINS!**

**DRY CONTACT & OPTO COUPLER INTERFACE BOARD OPTIONS**

**Typical Falcon Dry Contact Relay Board**

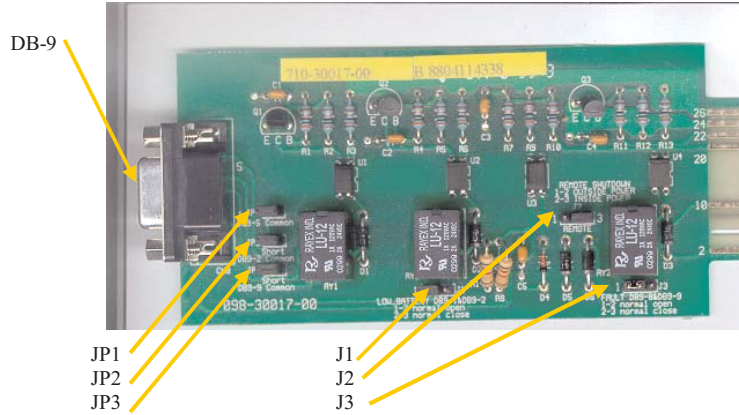

**PIN & JUMPER ASSIGNMENT FOR THE FALCON  
UA88374 RELAY OPTION BOARD  
(no on-bypass signal)**

PIN	DESCRIPTION
1	Low Battery ( When UPS reaches low battery, contact activates) (J1, 1-2 short = N.O) (J1, 2-3 short = N.C)
2	JP2 shorted = Low Battery common & all other shorted JP commons JP2 open = common for low battery only
3	Utility Loss N.O. ( At loss of utility voltage, contact activates)
4	Utility Loss N.C. ( At loss of utility voltage, contact activates)
5	JP1 shorted = Utility Loss common & all other shorted JP commons JP1 open = Utility Loss common only
6	Remote Shutdown common
7	Remote Shutdown (J2, 1-2 short = outside power) (J2, 2-3 short = inside power) <u>1-2 shorted.</u> Applying an external 12V signal across the DB-9, pins six and seven, while the UPS is on battery, will turn the UPS off. <u>2-3 shorted.</u> Applying a short directly across the DB-9, pins six and seven, while the UPS is on battery, will turn the UPS off.
8	Alarm (Upon a UPS fault or failure the contact activates) (J3, 1-2 short = N.O.) (J3, 2-3 short = N.C.)
9	JP3 shorted = Alarm common & all other shorted JP commons JP3 open = Alarm common only

**PIN & JUMPER ASSIGNMENT FOR THE FALCON  
UA88376 RELAY OPTION BOARD  
(with on-bypass signal)**

DB-9F PIN & JUMPER ASSIGNMENTS	
PIN	DESCRIPTION
1	Low Battery ( When UPS reaches low battery, contact activates) (J1, 1-2 short = N.O) (J1, 2-3 short = N.C)
2	JP2 shorted = Low Battery common & all other shorted JP commons JP2 open = common for low battery only
3	Utility Loss N.O. ( At loss of utility voltage, contact activates)
4	Utility Loss N.C. ( At loss of utility voltage, contact activates)
5	JP1 shorted = Utility Loss common & all other shorted JP commons JP1 open = Utility Loss common only
6	Remote Shutdown common
7	Remote Shutdown (J2, 1-2 short = outside power) (J2, 2-3 short = inside power) <u>1-2 shorted.</u> Applying an external 12V signal across the DB-9, pins six and seven, while the UPS is on battery, will turn the UPS off. <u>2-3 shorted.</u> Applying a short directly across the DB-9, pins six and seven, while the UPS is on battery, will turn the UPS off.
8	On Bypass or Alarm (Upon the UPS going to bypass or a UPS failure the contact activates) (J3, 1-2 short = N.O.) (J3, 2-3 short = N.C.)
9	JP3 shorted = On bypass, Alarm common & all other shorted JP commons JP3 open = On bypass, Alarm common only

### Typical Falcon Opto-coupler Interface Card

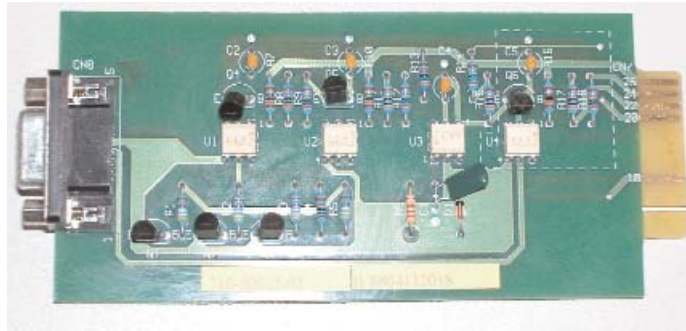

### PIN ASSIGNMENT FOR THE FALCON UA88373 OPTO-COUPLER OPTION BOARD (no-bypass signal)

PIN	DESCRIPTION
1	Not Used
2	Utility Loss (N.O.) (Closes upon utility loss)
3	Utility Loss (N.C.) (Opens upon utility loss)
4	Common for pins 2, 3 & 5
5	Low Battery (N.O.) (Closes at low battery)
6	Remote Shutdown Applying a +5-+12Vdc voltage level for >500ms, while the UPS is on battery will shutdown the UPS
7	Not Used
8	Not Used
9	Not Used

### OPTO Board Internal Circuitry

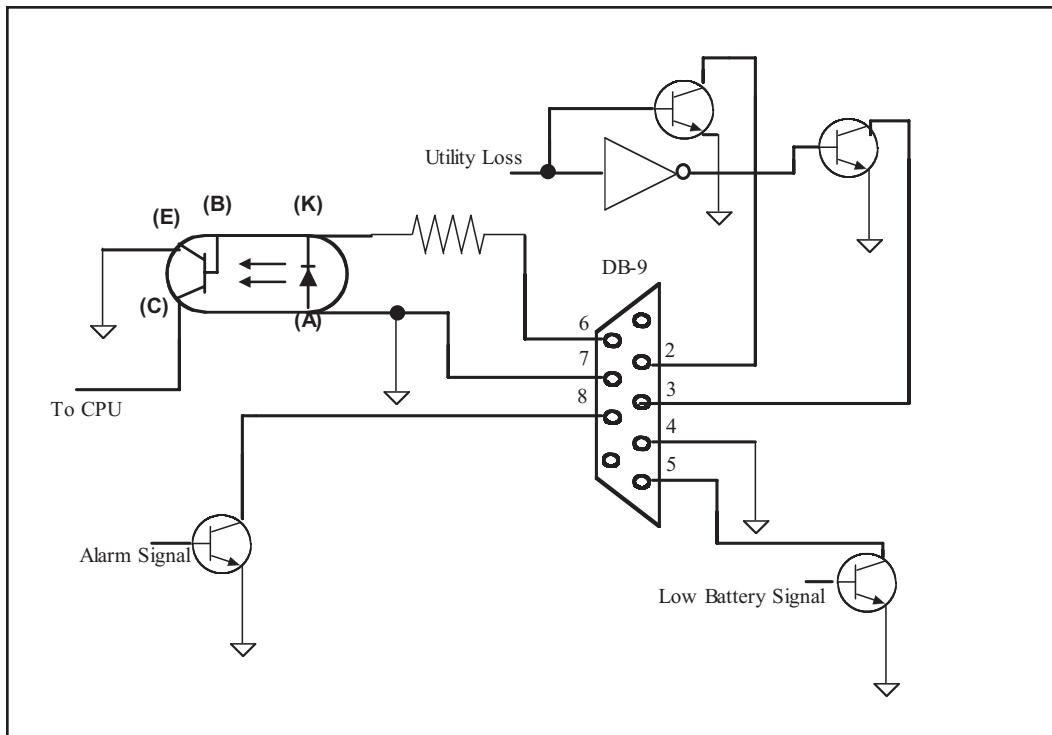

## APC Style Dry Contact Relay Board

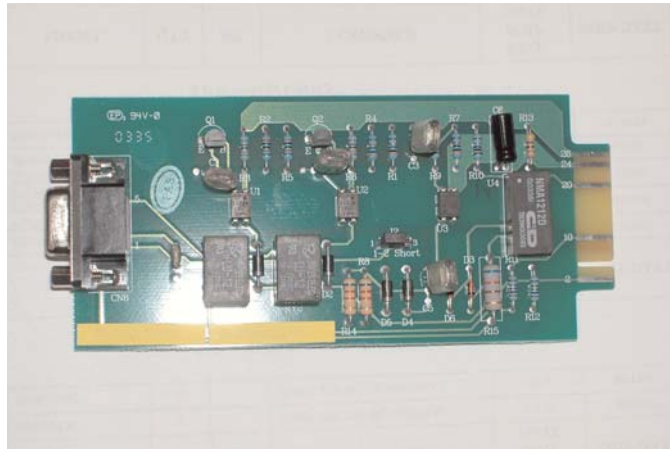

### PIN & JUMPER ASSIGNMENT FOR THE FALCON UA88377 RELAY OPTION BOARD (APC Style Board)

PIN	DESCRIPTION
1	Remote Shutdown (on battery operation only)
2	Remote Shutdown Common
3	Not Used
4	Low Battery Common
5	Low Battery (N.O.)
6	Not Used
7	Not Used
8	Utility Fail (+/- 10Vdc)
9	Utility Fail (+/- 10Vdc)

## Maintenance & Technical Support

### 1. **Care & Maintenance**

Falcon® SG Series UPSs are designed to be maintenance-free. They can be cleaned with a damp cloth or non-abrasive cleanser, providing the UPS is turned off and the input plug is disconnected from the utility source.

On a regular basis, check the vents to make sure they are kept free from accumulation of dust, dirt or lint.

### 2. **Battery Life vs. Temperature**

For full battery life, keep the UPS close to an ambient temperature of 77°F.

The batteries should never be exposed to temperatures below 40°F and above 104°F.

### 3. **Battery Replacement**

This UPS contains sealed maintenance-free batteries (VRLA). When situated in a typical office environment, with the proper charging and limited cycling, the batteries can last many years. **In home, office or computer room environments, the batteries should be replaced every three to five years.**

**Should you require battery replacement contact the Falcon Service Department (see page 20 for contact information).**

#### **WARNING**

Never attempt to service batteries. High voltage exists within the unit, which could cause electrical shock. **Servicing of batteries should be performed or supervised by personnel knowledgeable of batteries and the required precautions.** Keep unauthorized personnel away from batteries.

When replacing the UPS batteries, use the same number and type of batteries.

#### **NEVER**

A. **NEVER** dispose of batteries in a fire, as batteries will explode.

B. **NEVER** dispose of used batteries or the UPS in the trash or landfill as it is against federal and state laws. **The UPS and Batteries must be recycled.** For UPS and battery recycling information, please contact our service department for the name and address of the nearest battery recycling facility.

#### **CAUTION**

A. Do not open or mutilate the battery or batteries. Released electrolyte is harmful to the skin and eyes. It may be toxic.

B. A battery can present a risk of electrical shock and high short circuit current. **REFER ALL BATTERY SERVICING OR REPLACEMENT TO A QUALIFIED SERVICE TECHNICIAN. NEVER ATTEMPT TO REPLACE THE BATTERIES YOURSELF.**

The following precautions should be observed by a qualified technician when working with batteries.

1. Remove watches, rings, or other metal objects.
2. Use tools with insulated handles.
3. Wear rubber gloves and boots.
4. Do not lay tools or metal parts on top of batteries.

4. **Storing the UPS and Batteries**

Should you need to store the UPS for a long period, fully recharge the battery just prior to storage and recharge the battery every 4 months by plugging the UPS into a power outlet. It is recommended that the batteries charge for 24 hours after long-term storage.

5. **FCC Considerations**

Note: This equipment has been tested and found to comply with the limits for a Class A digital device, pursuant to part 15 of the FCC Rules. These limits are designed to provide reasonable protection against harmful interference when the equipment is operated in a commercial environment. This equipment generates, uses, and can radiate radio frequency energy and, if not installed and used in accordance with the instruction manual, may cause harmful interference to radio communications. Operation of this equipment in a residential area is likely to cause harmful interference in which case the user will be required to correct the interference at his own expense.

If this equipment does cause harmful interference to radio or television reception, which can be determined by turning the equipment off and on, the user is encouraged to try to correct the interference by one or more of the following measures:

- a. Reorient or relocate the receiving antenna.
- b. Increase the separation between the equipment and the receiver.
- c. Connect the equipment into an outlet on a circuit different from that to which the receiver is connected.
- d. Consult the dealer or an experienced radio/television technician for assistance.

## 6. Technical Support

Should your FALCON® Electric SG Series UPS require service or you need technical assistance, you can contact us at:

Falcon Electric Inc.  
5116 Azusa Canyon Road  
Irwindale, CA. 91706  
Service 800.842.6940  
Voice 626.962.7770  
Fax 626.962.7720  
Email: [service@falconups.com](mailto:service@falconups.com)  
[WWW.FALCONUPS.COM](http://WWW.FALCONUPS.COM)

Please have your UPS model, serial numbers and date of purchase on hand prior to your call. This information is located on the identification label on the rear panel of the unit. This information is essential in retrieving your unit's historical records. Should our service department determine service is required, you will be given a Return Material Authorization number (RMA) along with return shipping instructions.

The RMA number issued must appear on the outside of the shipping carton. The original shipping container must be used when returning any SG Series product. Falcon® Electric will not assume any responsibility for shipping damage. In the event of shipping damage, you will be notified of the damage and be instructed to file a claim with the freight carrier. You will be billed for all repairs caused by the shipping damage. You must submit a copy of our repair invoice to the carrier for reimbursement.

All units must be returned prepaid. The address and shipping instructions will be given to you at the time the RMA is issued.

## 7. Requesting Technical Information or Support

You may request technical information or support by email or telephone.

Please send your technical or support questions by email to:

**[SUPPORT@FALCONUPS.COM](mailto:SUPPORT@FALCONUPS.COM)**

You may contact a FALCON support engineer directly by calling the FALCON support line between 9:00 am and 4:00 pm PST.

**800.842.6940**

## 8. FALCON Web Support

Product data sheets, specification and owner's manuals are available in Adobe® Acrobat .PDF format on our corporate website.

**[WWW.FALCONUPS.COM](http://WWW.FALCONUPS.COM)**



# LIMITED NEW PRODUCT WARRANTY AGREEMENT

## GENERAL PROVISIONS

FALCON® ELECTRIC INC., hereby warrants product shipped under this agreement to be free from defective workmanship for a period of two years following date of shipment. This Limited New Product Warranty Agreement only applies to covered repairs to the product occurring within the United States and Canada.

## EXCLUSIONS:

The following are not covered by the Falcon Electric Limited New Product Warranty:

1. DAMAGE DUE TO ACCIDENTS, FRAUD, INTENTIONAL NEGLIGENCE, MISUSE, IMPROPER INSTALLATION, UNAUTHORIZED ADJUSTMENTS, MODIFICATIONS, ALTERATIONS, DISCONNECTION, TAMPERING: Accidents or acts of nature or other events beyond the control of Falcon Electric, damage from impact, contaminant, fire, or water, misuse of the product such as sustained overloading, improper installation or operation, operation in an uncontrolled environment.
2. DAMAGE DUE TO IMPROPER INSTALLATION OR LACK OF MAINTENANCE: Lack of proper maintenance as outlined in the owner's manual.
3. NORMAL MAINTENANCE: Cleaning, replacement of leaking or outdated batteries.
4. DAMAGE DUE TO ALTERATIONS: Alterations by changing or adding to the product by any unauthorized personnel or service organization.
5. DAMAGE CAUSED BY OTHER THAN ORIGINAL EQUIPMENT PARTS. Any malfunctions caused by the use of other than Falcon Electric original equipment parts such as batteries, line cords and plugs, output receptacles, or any other part.
6. BROKEN OR TAMPERED WARRANTY SEALS: Falcon Electric will deem all warranties null and void in the event warranty seals are broken or show signs of removal or tampering.
7. CONSEQUENTIAL DAMAGES: This Limited New Product Warranty does not cover any consequential or secondary damages that may be suffered as a result of usage of the product or the need to repair or replace a warranted part except to the extent coverage of such damage is required by the state whose law governs the Falcon Electric Limited New Product Warranty.
8. REPAIRS BY UNAUTHORIZED SERVICE ORGANIZATIONS OR PERSONNEL: Otherwise covered repairs when the prescribed repair is not performed by the Falcon Electric Service Center or by a Falcon Electric authorized third party service organization.
9. LIABILITY FROM USE OF THE PRODUCT: Liability for damage to property or injury or death of any person arising out of the operation, maintenance, or use of the product.
10. Warranty void if the battery is allowed to discharge below the minimum battery cutoff point. To prevent such discharge, remove the battery fuse, or switch the battery disconnect to the off position when the unit is to be stored without the AC power being supplied to the UPS for more than two days. The battery must be recharged every three to four months when not in use.
11. This product is not recommended, and Falcon Electric Inc. will not knowingly sell this product, for use with life support and other designated "critical devices". ANY SUCH USE BY A USER AUTOMATICALLY VOIDS AND DISCLAIMS ANY AND ALL WARRANTIES, INCLUDING ANY IMPLIED WARRANTY OF MERCHANTABILITY, IMPLIED WARRANTY OF FITNESS FOR A PARTICULAR PURPOSE, AND EXPRESS WARRANTIES THAT THIS PRODUCT WILL CONFORM TO ANY AFFIRMATION OR PROMISE, FOR THIS PRODUCT AND THE USER AGREES THAT IN NO EVENT SHALL FALCON ELECTRIC INC. BE LIABLE FOR CONSEQUENTIAL OR INDIRECT DAMAGES.

## LIMITS OF LIABILITY:

LIMITATION OF LIABILITY: THERE IS NO LIABILITY FOR INCIDENTAL OR CONSEQUENTIAL LOSS OR DAMAGE UNDER THESE WARRANTIES INCLUDING BUT NOT LIMITED TO, LIABILITY FOR INJURY, LOSS OF LIFE, PROPERTY DAMAGE, LOSS OF USE, LOSS OF DATA, LOSS OF TIME, INCONVENIENCE OR COMMERCIAL LOSS, OR BREACH OF IMPLIED OR EXPRESSED WARRANTIES. ANY AND ALL SUCH LIABILITY IS EXPRESSLY EXCLUDED. IN NO EVENT SHALL FALCON ELECTRIC BE RESPONSIBLE FOR ANY AMOUNT EXCEEDING THE ACTUAL MARKET VALUE OF THE PRODUCT. Some states do not permit the exclusions of limitations of incidental or consequential damages, so these limitations may not apply to you.

## TRANSFER:

This Falcon Electric Limited New Product Warranty is not transferable in the event of the product ownership being transferred during the warranty coverage period.

## ITEM COVERAGE:

Effective January 1, 2000, FALCON® ELECTRIC hereby warrants product shipped under this Agreement to be free from defective workmanship for a period of two years following date of shipment. Coverage under this Falcon Electric New Product Warranty Agreement commences with the date of shipment defined as the date on the Bill of Lading. If no Bill of Lading is issued, the date of shipment shall be shown on seller's shipping document. The Falcon Electric Limited New Product Warranties expire one year from the aforementioned commencement date. Falcon Electric Inc. reserves the right to make changes, additions, and/or other improvements in its products without incurring any obligation to install them on its products previously sold. This Warranty is valid for product as sold.

1. For product located in the continental United States and Canada deemed by Falcon Electric to be covered under this warranty, Falcon Electric will pay shipping costs associated with the return and repair of product under the following conditions only:
  - a. Falcon Electric will pay shipping costs both to and from our U.S. Service Center for the first 30 days from the original date of invoice. During this 30 day period, Falcon Electric may elect to ship a new unit to replace the defective product.
  - b. After the first 30 days and up to 90 days from the original date of invoice, the end-user is responsible for shipping costs associated with sending the defective unit to the Falcon Electric U.S. Service Center. Falcon Electric will pay shipping costs associated with returning the repaired product to the end-user. During this 60 day period Falcon Electric may elect to offer a loaner unit, providing the end-user agrees to pay for all shipping costs associated with transportation of the loaner unit both from and return to the Falcon Electric U.S. Service Center.
  - c. All shipping costs for product submitted beyond 90 days of the original date of invoice is the responsibility of the end-user.

Model Number	SG2K-1T SG2K-1T-HW	SG2K-2T SG2K-2T-HW	SG3K-1T SG3K-1T-HW	SG3K-2T SG3K-2T-HW	SG2K-2TX SG2K-2TXI <sup>1</sup>	SG3K-2TX SG3K-2TXI <sup>2</sup>
Nominal VA	2000		3000		2000	3000

### Electrical Input

Nominal AC Voltage	120V	230V	120V	230V	230V	
AC Voltage Range	87 – 140V	170 – 275V	87 – 140V	170 – 275V	170 – 275V	
Current – Amps	14.2	7.4	21.4	11.2	7.5	11.3
Frequency	50/60 Hz ± 5% (Auto – Tracking)					
Power Factor Correction	> 0.95					
Efficiency (Typical)	> 86%				> 85%	

### Electrical Output

Watts	1400		2100		1400		2100	
AC Voltage (Switchable)	100V 110V 115V 120V	200V 220V 230V 240V	100V 110V 115V 120V	200V 220V 230V 240V	120V 208V 220V 230V 240V <small><sup>1</sup>(700W split-phase, each 5-20R)</small>	208V 220V 230V 240V	120V 208V 220V 230V 240V <small><sup>2</sup>1050W split-phase, each 5-20R)</small>	208V 220V 230V 240V
Frequency	50/60 Hz (Auto Tracking)							
Frequency Stability	± 0.3% (Battery Mode)							
Voltage Regulation	± 2%				± 5%		± 3%	
Step Load Change	± 7% for 100% load variation							
Harmonic Distortion	< 3% Linear Load, < 5% Non -Linear Load							
Overload	105% load for 50 Seconds							
Crest Ratio	3:1							

### Battery

DC Voltage	72V		96V			
Type	12V, 7AH Sealed Lead Acid Maintenance-Free					
Back Up Time @ Full Load	7 Minutes		5.5 Minutes		7 Minutes	5.5 Minutes
@ 1/2 Load	20 Minutes		15 Minutes		20 Minutes	15 Minutes
Recharge Time	8 Hours to 90%					

Battery times are approximate.

### Transfer Time

Line Fails/Recovers	Zero	
UPS to Bypass or Reverse	< 4ms	
After Overload	Auto Transfer to UPS	

### Electrical Connections

Input - T Models	6' Cord with 5-20P	6' Cord with 6-20P, L6-20P or Schuko	6' Cord with L5-30P	6' Cord with 6-20P, L6-20P or Schuko	6' Cord with 6-20P, L6-20P or Schuko
-HW Models	Hardwire				Hardwire Not Available
Output -T Models	(6) 5-15R or (3) 5-15R & (2) 5-20R	(6) IEC 320 or (1) L6-20R	(6) 5-15R or (3) 5-15R & (2) 5-20R	(6) IEC 320 or (1) L6-20R	(2) 5-20R & (1) L6-20R
-HW Models	Hardwire				Hardwire Not Available

Contact the factory for other input/output options.

### Environmental

Operating Temperature	0° C - 40° C (32° F to 104° F)	
Humidity	10% to 95% Non – Condensing	
Altitude	7,000 Feet	
Cooling	Low Velocity Forced Air Fans	
Audible Noise @ 1 Meter	<50dBA	

### Controls and Indicators

LED	Line, Inverter, Battery Reserve, Load, Bypass, Alarm, Crest , Battery & Load Capacity Level
Audible Alarms	DC Mode, Low Battery, Over/Under Voltage, Over/Under Frequency, High Temp., Over Load, Fault Alarm
Communications	RS-232 Serial Port (Bundled UPSilon 2000 Software)

### Mechanical

Dimensions H x W x D inches (mm)	13.8 x 7.6 x 18.9 (350 x 193 x 480)		13.8 x 7.6 x 30.0 (350 x 193 x 720)
Weight lb. (kg)	68.4 (31)	81.4 (37)	150.0 (68)
Agency Listing	-1T Models: UL 1778, CUL, FCC Class A -HW Models: UL 1778 & CUL pending -2T Models (except –HW models): UL 1778, CUL, CE available with Schuko plug only		

### Available Options

Option A	60 Hz to 50 Hz Frequency Conversion
Option B	50 Hz to 60 Hz Frequency Conversion
Option C	SNMP/HTTP Network Card (Internal)
Option D	Standard Contact Closure Interface Card
Maintenance Bypass	Make-Before-Break External Wrap Around
External Battery Packs	Extended Run Time Battery Packs (minutes to hours)
Fast Battery Charger	Fast Charger internal to the Extended Battery Pack Cabinet (Required for battery times 2 hours or more.)