

FALCON® ELECTRIC, INC.

ED Series™ UPS Plus® User's Guide

UNINTERRUPTIBLE POWER SYSTEM
FOR MODELS:

ED-1000-1
ED-1500-1
ED-2000-1



FALCON® ELECTRIC, INC.
5116 Azusa Canyon Road
Irwindale, CA 91706
Tel. 626-962-7770
Fax. 626 962-7720



WWW.FALCONUPS.COM
800.842.6940

The information contained herein is the property of FALCON® ELECTRIC. This information is proprietary, confidential, and not to be disclosed, disseminated or used except for the purpose provided by FALCON® Electric, Inc.

TABLE OF CONTENTS

Important Safety Instructions (READ FIRST)	1
Chapter 1.						
ED Series UPS Overview	2
Model Cross Reference Table	2
Block Diagram	3
Selection Guide	4
Chapter 2.						
Installation	5
Inspecting the Equipment	5
UPS Setup	5
Chapter 3.						
Controls, Displays & Functions	6
Front Panel Diagram & Description	6
Front Panel LED Functions	6
Rear Panel Diagram & Description	7
Chapter 4.						
Communications Interface	8
Signals & Interfacing	8
Chapter 5.						
Operation	9
Step By Step Operating Procedure	9
Operational Mode Table	10
Chapter 6.						
Maintenance & Technical Support	11
Care & Maintenance	11
Battery Life vs. Temperature	11
Battery Replacement	11
Storing the UPS and Batteries	12
FCC Considerations	12
Technical Support & RMA Procedure	13
Requesting Technical Information or Support	13
FALCON Web Support	13
Warranty	14

IMPORTANT SAFETY INSTRUCTIONS

SAVE THESE INSTRUCTIONS

This manual contains important instructions which must be followed during the installation, operation and maintenance of this UPS and its batteries. Please read all instructions before operating this equipment and save this manual for future reference.

CAUTION

All of the models presented herein are designed for installation and use in a controlled environment free of contamination.

CAUTION

This UPS utilizes voltage that may be hazardous. Do not attempt to disassemble. This unit contains no user replaceable parts. Refer all servicing to Falcon Electric, Inc.

CAUTION

This UPS is not intended to be used in conjunction with life support or operating room equipment.

CAUTION

Always unplug this UPS prior to cleaning and never apply liquid or spray detergent on the UPS.

CAUTION

Never attempt to service batteries. High voltage exists within the unit, which could cause electrical shock. Servicing of batteries should be performed or supervised by personnel knowledgeable of batteries and the required precautions. Keep unauthorized personnel away from batteries. When replacing the UPS batteries, use the same number and type of batteries.

IMPORTANT

Allow at least 24 hours, after the UPS is first installed and turned on, to fully charge the internal battery and assure the maximum backup time is available.

DO NOT

DO NOT plug this UPS into its own output as this may damage the UPS.

DO NOT remove or unplug the input cord when the UPS is turned on. This removes the safety ground from the UPS and the equipment connected to the UPS.

CAUTION

This UPS contains its own energy source (batteries). The output receptacles may carry live voltage even when the UPS is not connected to an AC source.

CHAPTER 1

ED Series UPS - Overview

Congratulations! You have selected the highest quality protection for your computer today. The FALCON® ED Series UPS offers a quiet and compact package with superior performance you can depend on. You now own a member of the ED family which is a proud part of the very reliable and versatile FALCON® products.

This User's Guide is provided with your new ED unit. It will enhance your understanding of the product and its functions. Read this handbook carefully in the order it is presented prior to operating your unit. This will save you time and effort in your installation and application. The illustrations will also familiarize you with the ED's operating modes and indications. Always operate the unit within the guidelines and specifications given to maximize the unit's efficiency and lifetime. Also, your understanding of the product is essential in providing you years of service for your back-up power requirements.

Refer to the cross-reference table below to understand which unit with its power capability corresponds to your particular model number.

CROSS REFERENCE TABLE

MODEL NUMBER	OUTPUT POWER (VA)
ED-1000-1	1000
ED-1500-1	1500
ED-2000-1	2000

The FALCON® ED Series represents one of the smallest and most compact units of the FALCON® UNINTERRUPTIBLE POWER SYSTEM (UPS) product line. In the tradition of all FALCON® products, it maintains the highest reliability and the most complete on-line, sinewave power protection available. An on-line, sinewave UPS is the only total solution to virtually any power problem. It effectively provides just what it says, UNINTERRUPTIBLE POWER. There is no break, transient or glitch in source transfer during a power failure because THERE IS NO TRANSFER.

The FALCON® ED SERIES is engineered with the latest MOSFET/PWM technology for high efficiency and reliability.

Refer to the simplified block diagram, Figure 1, for a system description. The AC source is rectified and provides energy for the DC + Choppers and a float charge to a standby battery. These DC Choppers then supply the power to operate the DC/AC Inverter.

During a utility power-loss, the AC rectification and battery charging capabilities of the UPS become inactive. The fully-charged battery, however, supplies the necessary power requirement to maintain the remaining system blocks.

The FALCON® ED on-line topology is unique to other on-line system because it is designed to meet the needs of non-linear loads. Your computer, with its switching power supply, is considered a non-linear load which can be very abusive to most power protection equipment and could decrease its life-expectancy. The FALCON® ED unit is specially devised to accept these loads and protect them efficiently without any of the output waveform degradation common to other UPS.

Referring again to the figure below, you will notice a built-in safeguard. If the unit inadvertently experiences an extreme over-temperature situation that causes inverter malfunction, it will switch over to a filtered emergency bypass line to ensure continuous power to the computer load. In the event the UPS is overloaded for 15 seconds, it will shutdown completely.

FIGURE 1: FALCON ED SERIES BLOCK DIAGRAM

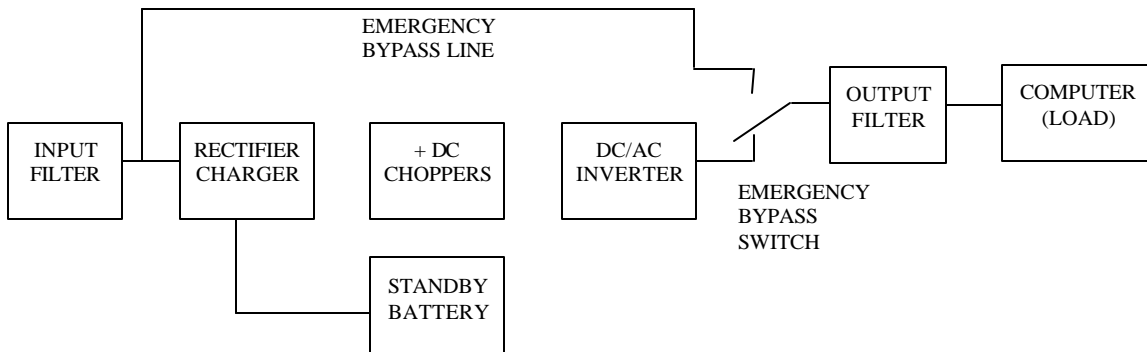

MODEL SELECTION GUIDE

Model Number	ED-1000-1	ED-1500-1	ED-2000-1
Nominal VA	1000	1500	2000

Electrical Input

AC Voltage, +10% -20%	120V	120V	120V
Current-Amps	10.4	15.6	20.8
Frequency Range	47 – 450	47 – 450	47 - 450

Electrical Output

AC Voltage, ± 3%	120V	120V	120V
Watts @ 50 or 60 Hz	700	1050	1400
Watts @ 400 Hz	595	892	1190
Current-Amps @ 50/60 Hz	8.3	12.5	16.7
Current-Amps @ 400Hz	7.1	10.6	14.2
50/60 Hz Non – Linear Repetitive Peak (Amps)	20	30	40
400 Hz Non – Linear Repetitive Peak (Amps)	14.2	21.3	28.3
Total Harmonic Distortion	< 3% @ 100% Linear Load, < 5% @ 100% Non – Linear Load		
Overload	200% for 0.5 Seconds, 120% for 30 Seconds		
Dynamic Response	± 5% RMS for 100% Step Load Change, 1ms Recovery Time		
Output Protection	Short Circuit and Overload		

Battery

Type	Sealed Lead Acid Maintenance-Free		
Back Up Time @ Full Load	8 Minutes		5 Minutes
@ 1/2 Load	20 Minutes		14 Minutes

Battery times are approximate.

Electrical Connections

Input	6' Cord with 5-15P	8' Cord with 5-20P	8' Cord with L5-30P
Output	(4) 5-15R	(4) 5-15R	(4) 5-15R

Environmental

Operating Temperature	0° C to 35° C (32° F to 95° F)		
Humidity	10% to 95% Non – Condensing		
Altitude	7,000 Feet		
Cooling	Low Velocity Forced Air Fans		
Audible Noise @ 1.5 Meters	49dBA		54dBA

Controls and Indicators

Sequenced LED's	Load Level
Single LED	Utility Present, Low Battery, Summary Alarm, Inverter On
Audible Alarms	Utility Interrupt, Inverter Failure, Overload, Low Battery
Communications	Dry Contact Closures on Utility Loss & Low Battery via 9 Pin "D" Connector

Mechanical

Dimensions H x W x D inches (mm)	13.5 x 6.25 x 19.4 (342.9 x 158.8 x 492.8)		
Weight lb. (kg)	41 (18.6)	64 (29)	64 (29)
Design Standard	UL Listed 1778, FCC Class A		

CHAPTER 2

Installation

Inspecting the Equipment

If any FALCON® equipment has been damaged during shipment, keep the shipping cartons and packing materials for the carrier and file a claim for shipping damage. If you discover damage after acceptance, file a claim for concealed damage.

To file a claim for shipping damage or concealed damage:

- 1) File with the carrier within 15 days of receipt of the equipment.
- 2) Send a copy of the damage claim within 15 days to the Falcon® Service Department.

UPS Setup

1. Verify that the following is included in the UPS shipping carton:
UPS, Owner's Guide and power cord of not attached to the unit.
2. Verify that the UPS unit is configured for the proper input/output voltage. This information is stated on the nameplate label located on the rear panel of the unit.
3. This UPS has been shipped with the battery connection fuse removed to meet new transportation regulations.

IMPORTANT

THE BATTERY CONNECTION FUSE MUST BE INSTALLED PRIOR TO PLUGGING IN AND ATTEMPTING TO TURN ON THE UPS.

4. Select a suitable location for the UPS, near enough to the computer or equipment to allow connection of the equipment power plug to the receptacles located on the rear panel of the UPS.

IMPORTANT

5. **DO NOT BLOCK UPS AIR VENTS. THE UPS MUST NOT BE INSTALLED IN AN ENCLOSED AREA.**
6. If you have not already done so, connect the equipment to be protected to the UPS output receptacles located on the rear panel. Verify the connected equipment does not exceed the rated output (in watts) of the UPS.
7. Plug the UPS power cord into the nearest grounded wall outlet. If the UPS does not power up automatically, depress and hold the control button located on the UPS front panel until the UPS turns on.

CHAPTER 3

Controls, Displays & Functions

FRONT PANEL

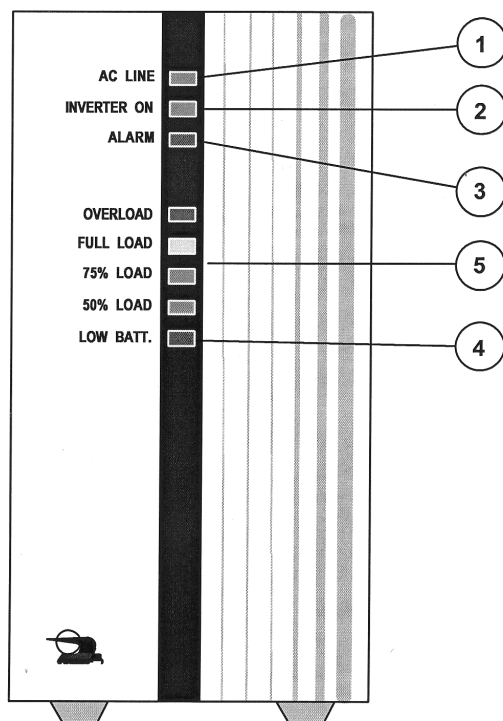

1. **AC- AC LINE INDICATOR**
This green LED turns on when the utility AC is present.
2. **INV- INVERTER OPERATING**
The LED turns green when the UPS inverter is turned on. This LED normally turns on a few seconds after the AC line indicator LED and remains on during both utility and battery operation.
3. **ALM- ALARM STATUS INDICATOR**
This red LED turns on and a continuous audible alarm is sounded when the UPS is overloaded or has failed. Should this occur, check the load level and correct any overload condition if present. During this condition, UPS load outlets will be powered by filtered utility bypass power. Should the unit not be overloaded, call FALCON® support for further assistance.
4. **LOW BATT.- LOW BATTERY WARNING INDICATOR**
The red LED will turn on when the UPS is operating in battery mode and the low battery level warning point has been reached. Typically one minute of battery runtime remains after the LED turns on.

5. OVERLOAD/ FULL LOAD/ 66% LOAD/ 33% LOAD-
 Adjacent to the red low battery LED is the green 33% load LED.
 Adjacent to the green 33% load LED is the green 66% load LED.
 Adjacent to the green 66% load LED is the yellow 99% load LED.
 Adjacent to the yellow 99% LED is the red overload LED. All overload
 conditions must be corrected immediately.

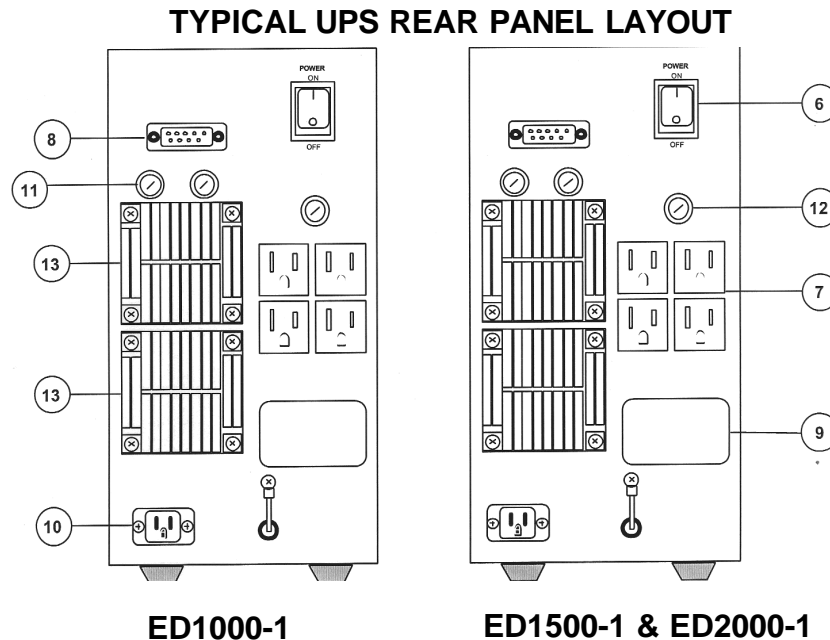

6. Power Switch
 This switch turns the UPS on and off. When the switch is in the off position, it is not recharging the internal batteries.
7. Output Receptacles (typically (4) NEMA 5-15R
8. DB-9 Interface Connector
 This connector gives access to the UPS contact closure status interface. Please reference page 9 of this manual for details.
9. UPS Model Identification Label.
10. Inlet for Input Line Cord on ED1000-1 only. Line cord permanently attached to ED1500-1 and ED2000-1.
11. Input Fuse Holders (typical)
 Depending on UPS configuration, the number and position of these fuse holders may vary. **ALWAYS REPLACE FUSES WITH SAME TYPE AND RATING.**
12. Output Fuse Holder (typical)
 Depending on UPS configuration, the number and position of these fuse holders may vary. **ALWAYS REPLACE FUSES WITH SAME TYPE AND RATING.**
13. Cooling Fans (2)
 Cooling fans draw cool air from the outside of the rear panel and exhaust it out through slots in the UPS front panel. **ALWAYS KEEP COOLING FAN AND FRONT PANEL VENTS CLEAR OF DEBRIS. DO NOT OPERATE THE UPS IN AN ENCLOSED SPACE.**

CHAPTER 4

DB-9 COMMUNICATIONS INTERFACE

SIGNALS AND INTERFACING

The **FALCON**® ED unit is designed to be compatible with all sophisticated operating systems when they feature a Shutdown monitoring function. These signals are made available through a DB-9 subminiature, female connector at the rear of the unit. Interfacing cables are available. Below is a diagram of the 9-pin jack and its pin-out:

- 1 - **+12V SOURCE RETURN**
- 2 - **UTILITY INTERRUPT, Normally Open Contact**
- 3 - **UTILITY INTERRUPT, Normally Closed Contact**
- 4 - **COMMON, Contact Closures**
- 5 - **LOW BATTERY, Normally Open Contact**
- 6 - **AUTOMATIC SHUTOFF CIRCUIT (ASC)**
- 7 - **ASC RETURN**
- 8 - **+ 12VDC @ 30ma SOURCE**
- 9 - **- 12VDC @ 30ma SOURCE**

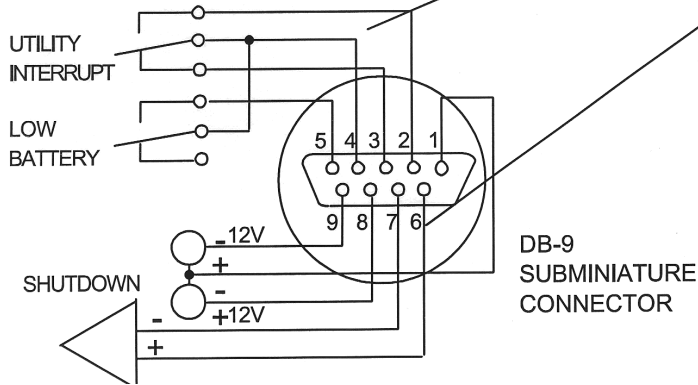

NOTES:

1. Contacts rated 2A @ 28VDC.
2. A +5 to +12VDC signal applied to pin 6 with respect to pin 7 for at least one millisecond when no utility power is present will cause the ED to shutdown. The current drawn is about 2ma @ 5VDC and 5ma @ 12VDC. The 12VDC source provided at pins 8 to 1 may be utilized for this function. Upon the return of utility power, restart is automatic.
3. NORMAL contact states are maintained with system power "ON" and the Inverter operational or with system power completely "OFF".

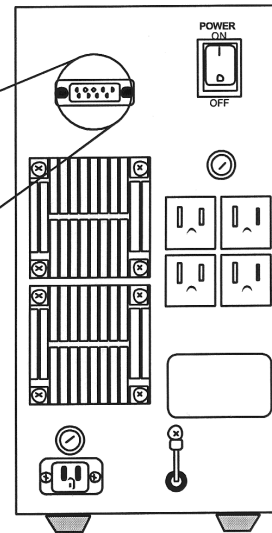

CHAPTER 5

OPERATION

The FALCON® ED unit is very simple to use.

1. Be sure the power cord is plugged into the nearest available, appropriately rated wall outlet.
2. Activate the power switch to the "ON" position.
3. The green AC LED illuminates.
4. The green INV LED illuminates.
5. Leave the power switch "ON" and unplug the power cord from the wall. This will simulate a power loss to test battery operation.
6. The green AC LED will shut off.
7. An intermittent audible alarm will sound.

The system will continue to operate. If this were to continue for a long while, the red LOW BATTERY light would illuminate, indicating that battery back-up time is ending and system shutdown is imminent. The intermittent alarm will become continuous at this point. The ED unit will automatically shut itself off to avoid excessive battery discharge. When power returns, normal operation of the UPS resumes without any operator adjustment.

The duration of actual battery back-up time and the low battery condition varies depending on the amount of load, charge on the battery, and condition of the battery. See SPECIFICATIONS on page 4 for approximate backu[times.

8. Plug the system power cord in again and turn the power switch "OFF".
9. Turn off the devices you wish to plug into the UPS. Plug them into the outlets labeled UPS OUTPUT at the rear of the UPS.
10. Activate the ED unit power switch to the "ON" position.
11. Turn "ON" each of your devices.
12. Some of the LOAD indicators may illuminate. The amount of load determines the actual number of indicators lit. The bottom green L.E.D. signifies approximately 50% of load capacity. The second green L.E.D. represents approximately 75% of load capacity. If the yellow L.E.D. illuminates, full load has been achieved. If the red light illuminates, an OVERLOAD condition is present. If this situation continues for about 15 seconds, the unit will automatically shut off.
If the system overheats or the Inverter should fail, the unit automatically transfers the load to a filtered bypass line, sounds a continuous alarm and the red ALM light will illuminate.

To escape this condition, the problem must first be corrected then turn the UPS power switch "OFF", then back "ON".

It is recommended that you leave the ED unit power switch "ON" at all times and switch your devices "OFF" individually. This will insure that your batteries are always at a maximum charged state.

WARNING

The power switch acts as a system ON/OFF switch. When this switch is turned "OFF", power is lost to the entire unit including all outlets at the rear of the UPS, since the battery circuit is also disabled.

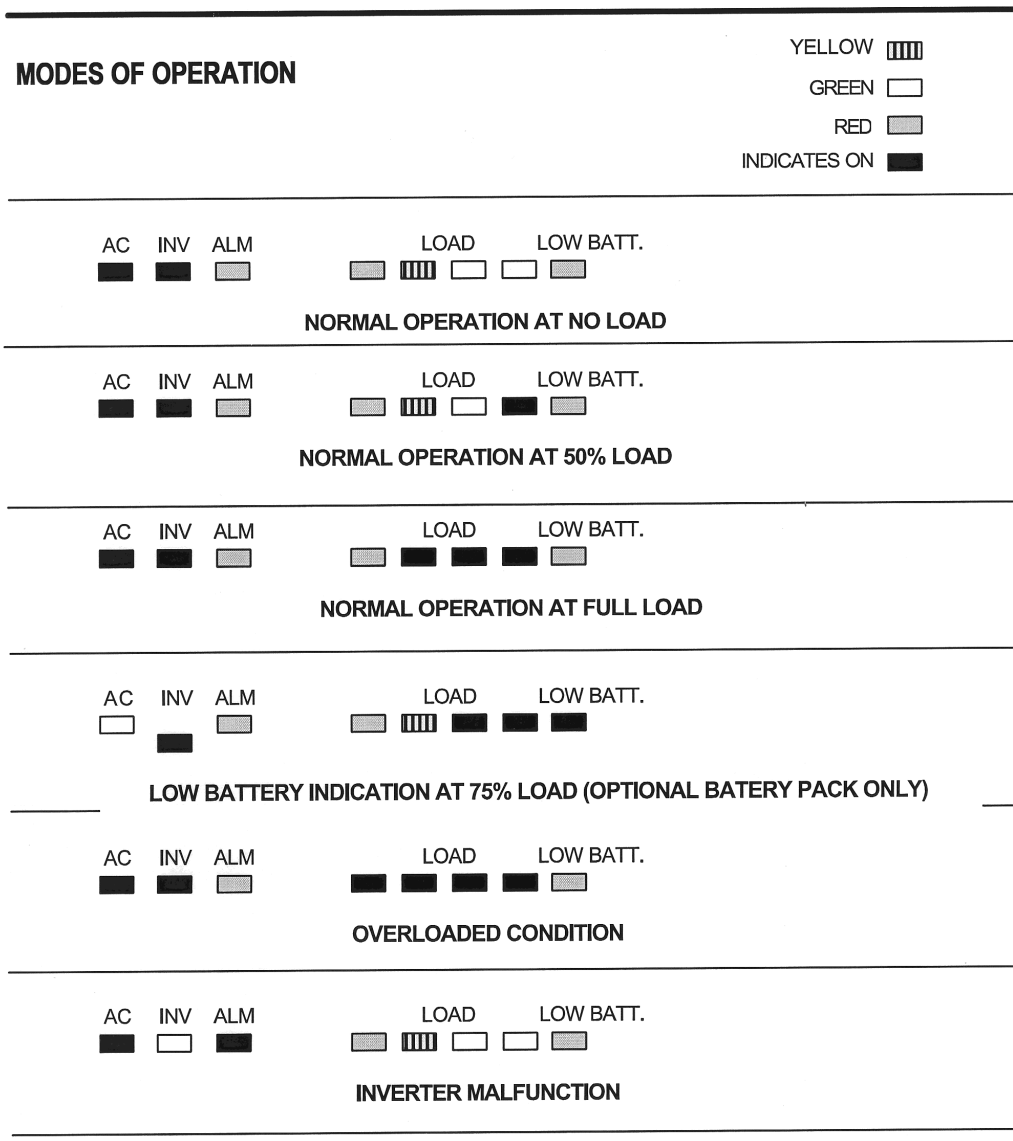

CHAPTER 6

Maintenance & Technical Support

1. **Care & Maintenance**

Falcon® ED Series UPSs are designed to be maintenance-free.

They can be cleaned with a damp cloth or non-abrasive cleanser, providing the UPS is turned off and the input plug is disconnected from the utility source.

On a regular basis, check the vents to make sure they are kept free from accumulation of dust, dirt or lint.

2. **Battery Life vs. Temperature**

For full battery life, keep the UPS close to an ambient temperature of 77°F.

The batteries should never be exposed to temperatures below 40°F and above 85°F.

3. **Battery Replacement**

This UPS contains sealed maintenance-free batteries (VRLA). When situated in a typical office environment, with the proper charging and limited cycling, these batteries can last many years. **In home, office or computer room environments, the batteries should be replaced every three to five years.**

WARNING

Never attempt to service batteries. High voltage exists within the unit, which could cause electrical shock. **Servicing of batteries should be performed or supervised by personnel knowledgeable of batteries and the required precautions.** Keep unauthorized personnel away from batteries.

When replacing the UPS batteries, use the same number and type of batteries.

NEVER

A. **NEVER** dispose of batteries in a fire, as batteries will explode.

B. **NEVER** dispose of used batteries or the UPS in the trash or landfill as it is against federal and state laws. **The UPS and Batteries must be recycled.**

For UPS and battery recycling information, please contact our service department for the name and address of the nearest battery recycling facility.

CAUTION

A. Do not open or mutilate the battery or batteries. Released electrolyte is harmful to the skin and eyes. It may be toxic.

B. A battery can present a risk of electrical shock and high short circuit current. **REFER ALL BATTERY SERVICING OR REPLACEMENT TO A QUALIFIED SERVICE TECHNICIAN. NEVER ATTEMPT TO REPLACE THE BATTERIES YOURSELF..**

NECESSARY PRECAUTIONS

The following precautions should be observed by a qualified technician when working with batteries:

1. Remove watches, rings, or other metal objects.
2. Use tools with insulated handles.
3. Wear rubber gloves and boots.
4. Do not lay tools or metal parts on top of batteries

4. **Storing the UPS and Batteries**

Should you need to store the UPS for a long period, fully recharge the battery just prior to storage and recharge the battery every 6 months by plugging the UPS into a power outlet. It is recommended that the batteries charge for 24 hours after long-term storage.

5. **FCC Considerations**

This equipment generates and uses radio frequency energy and if not installed and used properly in strict accordance with the manufacturer's instructions, may cause interference to radio and television reception. All models covered in this manual have been tested and found to comply with the limits for a Class A computing device, in accordance with the specifications in FCC regulations, Part 15, Subpart J, which are designed to provide reasonable protection against such interference.

If this equipment does cause harmful interference to radio or television reception, which can be determined by turning the equipment off and on, the user is encouraged to try correcting the interference by one or more of the following measures:

- a. Reorient or relocate the receiving antenna.
- b. Increase the separation between the equipment and the receiver.
- c. Connect the equipment into an outlet on a circuit different from that to which the receiver is connected.
- d. Consult the dealer or an experienced radio/television technician for assistance.

6. **Technical Support**

Your FALCON® Electric ED Series UPS is backed by one of the finest customer service teams assembled. Write, call, fax or email should you require technical assistance or service.

FALCON ELECTRIC, INC.
5116 Azusa Canyon Road
Irwindale, CA. 91706
Voice 626.962.7770
Fax 626.962.7720
Service 800.842.6940
Email: service@falconups.com
WWW.FALCONUPS.COM

Should service be desired, you must first obtain a Return Material Authorization number (RMA) and return shipping instructions from our customer service department. Please have your UPS model, serial numbers and date of purchase on hand prior to the call. This information is located on the identification label on the rear panel of the unit. This information is essential in retrieving your unit's historical records.

The RMA number issued must appear on the outside of the shipping carton. The original shipping container must be used when returning any ED Series product. Falcon® Electric will not assume any responsibility for shipping damage. In the event of shipping damage you will be charged for repairs due to the damage.

All units must be returned prepaid. The address and shipping instructions will be given to you at the time the RMA is issued.

7. **Requesting Technical Information or Support.**

You may request technical information or support by email or telephone.

Please send your technical or support questions by email to:

SUPPORT@FALCONUPS.COM

You may contact a FALCON support engineer directly by calling the FALCON support line between 9:00 am and 4:00 pm PST.

626.962.7770

8. **FALCON Web Support**

Product data sheets, specification and owner's guides are available in Adobe .PDF format on our corporate website.

WWW.FALCONUPS.COM

WARRANTY

1. TIME AND SCOPE OF WARRANTY:

- 1.1 FALCON® hereby warrants parts shipped under this Agreement to be free from defective workmanship for a period of **one year** following date of shipment. Accidental damage, misuse or normal wear and tear shall not be construed as a defect.
- 1.2 The date of shipment as used herein will be the date on the Bill of Lading. If no Bill of Lading is issued, the date of shipment shall be shown on seller's shipping document.
- 1.3 No provision of this warranty shall cover equipment which has been altered or modified from the original specifications manufactured unless authorized in writing.
- 1.4 No provision of this warranty shall cover batteries. However, battery manufacturer's warranties will be passed through to the customer whenever applicable.

2. LIMITS OF "IN WARRANTY" SERVICE LIABILITY:

- 2.1 FALCON® is obligated during the in-warranty period to provide service and/or adjustments to equipment returned to the factory at the expense of buyer (the term "factory" as used here-in shall also include any field service centers which may be established by FALCON®) and to repair or replace any part(s) thereof which in the opinion of authorized FALCON® personnel are found to have been defective during the warranty period.
- 2.2 Equipment requiring in-warranty services must be returned to the factory with all transportation charges prepaid, clearly tagged, stating the nature of the trouble experienced, and the disposition of the equipment after repair. The equipment will be returned freight collect by FALCON® to the location specified via the best and least expensive carrier available or via customer's shipping instructions.
- 2.3 During the in-warranty period, no service charges shall be payable by the buyer for service performed other than for service necessitated by accident, misuse, theft, abnormal line or source voltage fluctuations, abnormal conditions of operation, damage by the elements or damage resulting from adjustments, repairs, modifications made by anyone other than FALCON® authorized personnel, or the buyer's failure to reasonably maintain the equipment.

THE FOREGOING WARRANTY IS EXCLUSIVE AND IS GIVEN AND ACCEPTED IN LIEU OF ANY AND ALL OTHER WARRANTIES, EXPRESSED OR IMPLIED, INCLUDING WITHOUT LIMITATION THE IMPLIED WARRANTIES OF MERCHANTABILITY AND FITNESS FOR A PARTICULAR PURPOSE. THE REMEDIES OF BUYER SHALL BE LIMITED TO THOSE PROVIDED HEREIN. IN NO EVENT WILL SELLER BE LIABLE FOR COLLATERAL OR CONSEQUENTIAL DAMAGES. No person is authorized to assume on behalf of FALCON® any obligation or liability in connection with the sale, warranty or service policy of any products manufactured and/or marketed by FALCON® beyond the warranty description on the face hereof.

3. FALCON® ELECTRIC reserves the right to make changes, additions, and/or improvements in its products without incurring any obligation to install them on its products previously sold. This Warranty is valid for FALCON® product as sold.