

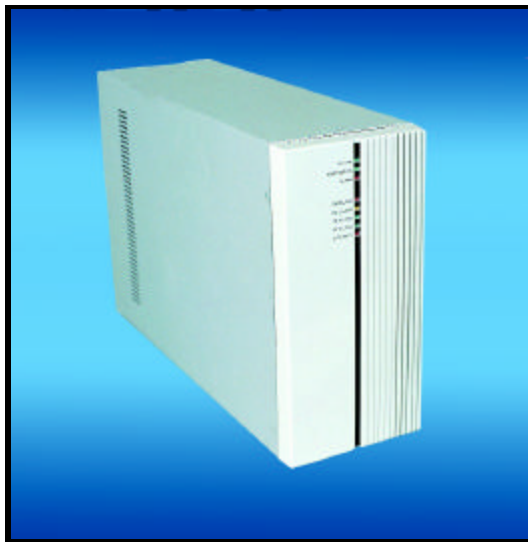

OWNER'S OPERATING MANUAL

**FREQUENCY CONVERTER &
UNINTERRUPTIBLE POWER SYSTEM**

**FOR MODELS:
ED3000-A
ED4000-A**



FALCON® ELECTRIC INC.
5116 Azusa Canyon Road
Irwindale, CA 91706
Tel. 626-962-7770
Fax. 626 962-7720

TABLE OF CONTENTS

Important Safety Instructions (READ FIRST)	1
Chapter 1, ED Series Overview	2
Input/Output Specifications Table	2
Block Diagram	3
Chapter 2, Installation	4
Inspecting the Equipment	4
Unit Setup	4
Chapter 3, Controls, Displays & Functions	5
Front Panel Diagram & Description	5
Front Panel LED Functions	5
Rear Panel Diagram & Description	6
Chapter 4, Communications Interface	7
Signals & Interfacing	7
Chapter 5, Operation	8
Step By Step Operating Procedure	8
Operational Mode Table	9
Chapter 6, Maintenance & Technical Support	10
Care & Maintenance	10
Battery Life vs. Temperature	10
Battery Replacement	10
Storing the UPS and Batteries	11
FCC	11
Technical Support & RMA Procedure	12
Requesting Technical Information or Support	12
FALCON Web Support	12
Brochure	13
Specifications	14

IMPORTANT SAFETY INSTRUCTIONS

SAVE THESE INSTRUCTIONS

This manual contains important instructions which must be followed during the installation, operation and maintenance of this unit and its battery options. Please read all instructions before operating this equipment and save this manual for future reference.

CAUTION

All of the models presented herein are designed for installation and use in a controlled environment free of contamination.

CAUTION

This UPS utilizes voltage that may be hazardous. Do not attempt to disassemble. This unit contains no user replaceable parts. Refer all servicing to Falcon Electric, Inc.

CAUTION

This unit is not intended to be used in conjunction with life support or operating room equipment.

CAUTION

Always unplug this device prior to cleaning and never apply liquid or spray detergent on the ED unit.

CAUTION

Never attempt to service batteries. High voltage exists within the unit, which could cause electrical shock. Servicing of batteries should be performed or supervised by personnel knowledgeable of batteries and the required precautions. Keep unauthorized personnel away from batteries. When replacing the optional ED batteries, use the same number and type of batteries.

IMPORTANT

If configured with batteries, allow at least 24 hours, after the ED is first installed and turned on, to fully charge the internal battery and assure the maximum backup time is available.

DO NOT

DO NOT plug this unit into its own output as this may damage the ED electronics. **DO NOT** remove or unplug the input cord when the ED is turned on. This removes the safety ground from the unit and the equipment connected to the ED.

CAUTION

When configured with optional batteries, the ED contains its own energy source (batteries). The output receptacles may carry live voltage even when the UPS is not connected to an AC source.

CHAPTER 1

ED Series - Overview

Congratulations! You have selected the ED Series Frequency Converter, Voltage Regulator and UPS. The FALCON® ED Series UPS offers a quiet and compact package with proven performance you can depend on.

This User's Guide is provided with your new ED unit. It will enhance your understanding of the product and its functions. Read this guide carefully in the order it is presented prior to operating your unit. This will save you time and effort in your installation and application. The illustrations will also familiarize you with the ED's operating modes and indications. Always operate the unit within the guidelines and specifications given to maximize the unit's efficiency and lifetime. Also, your understanding of the product is essential in providing you years of service for your back-up power requirements.

Refer to the table below to verify the input and output rating for your model.

MODEL	INPUT/OUTPUT SPECIFICATIONS		
	INPUT	OUTPUT	OUTPUT POWER
ED3000-A	120Vac, 47-420Hz	120Vac, 50 or 60Hz	2100 Watts
ED3000-A	120Vac, 47-420Hz	120Vac, 400Hz	1785 Watts
ED4000-A	120Vac, 47-420Hz	120Vac, 50 or 60Hz	2800 Watts
ED4000-A	120Vac, 47-420Hz	120Vac, 400Hz	2380 Watts

The FALCON® ED Series represents one of the smallest and most compact units of the FALCON® Frequency Converter and Uninterruptible Power Supply (UPS) product line. In the tradition of all FALCON® products, it maintains the highest reliability and the most complete on-line, sinewave power conversion and protection available. An on-line, sinewave converter is the only solution to AC line frequency conversion. With the addition of an optional external battery bank the ED models referenced in this manual will also provide true on-line UPS battery backup. There is no break, transient or glitch in source transfer during a power failure because THERE IS NO TRANSFER.

The FALCON® ED SERIES is engineered with the latest MOSFET/PWM technology for high efficiency and reliability.

Refer to the simplified block diagram, Figure 1, for a system description. The AC source is rectified and provides energy for the DC + Choppers and a float charge to the optional standby Battery. These DC Choppers then supply the power to operate the DC/AC Inverter. The inverter provides a new clean sinewave output at the factory configured output frequency.

When configured with an optional battery bank and during a utility power-loss, the AC rectification and battery charging capabilities of the UPS become inactive. The fully-charged battery, however, supplies the necessary power requirement to maintain the remaining system blocks.

The FALCON® ED on-line topology is unique to other on-line systems, in that, it is designed to meet the needs of non-linear loads. Equipment, configured with a switching power supply, is considered a non-linear load which can be very abusive to most power conversion and protection equipment, and could decrease its life-expectancy. The FALCON® ED unit is specially designed to accept these loads and protect them efficiently with minimal of the output waveform degradation.

For ED models configured with batteries, please refer again to the figure below, you will notice a built-in safeguard. If the unit has not been configured as a frequency converter, when it inadvertently experiences an extreme over temperature situation that causes inverter malfunction, it will switch over to a filtered emergency bypass line to insure

FIGURE 1: FALCON ED SERIES BLOCK DIAGRAM

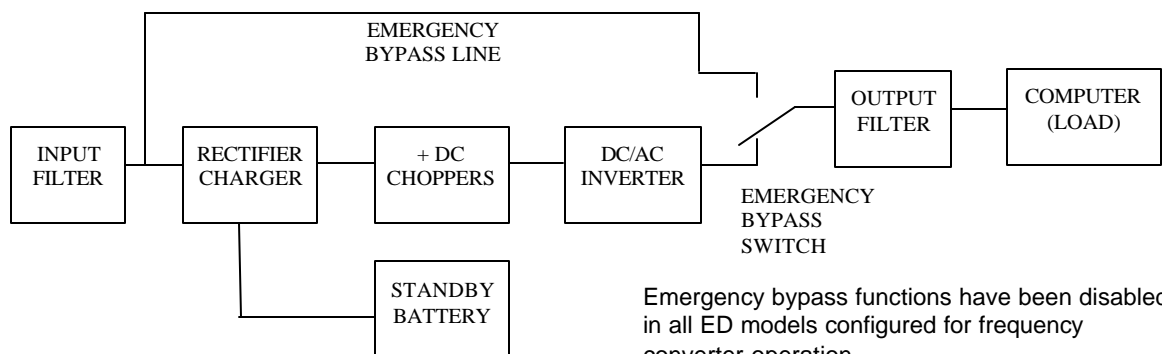

CHAPTER 2

Installation

Inspecting the Equipment

If any FALCON® equipment has been damaged during shipment, keep the shipping cartons and packing materials for the carrier and file a claim for shipping damage. If you discover damage after acceptance, file a claim for concealed damage.

To file a claim for shipping damage or concealed damage: 1) File with the carrier within 15 days of receipt of the equipment; 2) Send a copy of the damage claim within 15 days to the Falcon® Service Department.

ED Setup

1. Verify that the following is included in the ED shipping carton: ED Frequency Converter & UPS, Owner's Guide.
2. Verify that the ED unit is configured for the proper input/output voltage. This information is stated on the nameplate label located on the rear panel of the unit.
3. Select a suitable location for the ED, near enough to the computer or equipment to allow connection of the equipment power plugs to the receptacles located on the rear panel of the ED.
4. **DO NOT BLOCK UPS AIR VENTS. THE UPS MUST NOT BE INSTALLED IN AN ENCLOSED AREA.**
5. Connect the equipment to be powered to the ED output receptacles located on the rear panel. Verify that the connected equipment does not exceed the rated output (in watts) of the ED Series unit

IMPORTANT

This ED model is designed for input and output hardwire connections. Two conduit connector holes are provided on the lower portion of the rear panel. The hardwire terminal block is located inside the ED unit and can be accessed by removing the (16) screws securing the units top cover. Remove the top cover: the terminal block is located on the upper left side of the units center panel. Pay special attention to the ED input voltage configuration and verify the input voltage is correct prior to hardwiring the unit. Make the input and output connections per the picture below.

USE COPPER WIRE ONLY.

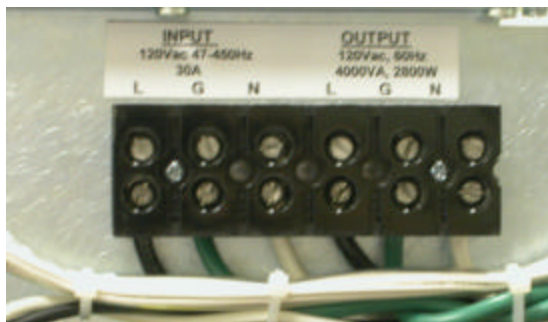

CHAPTER 3

Controls, Displays & Functions

NOTE: Reference page 10 for more details

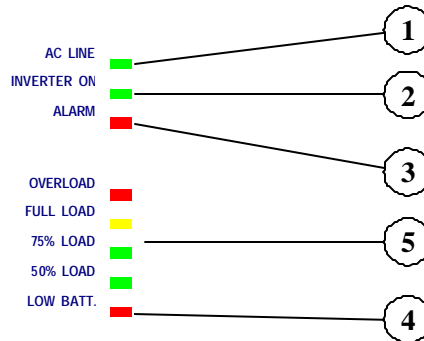

1. **AC- AC LINE INDICATOR**
This green LED turns on when the AC source is present.
2. **INV- INVERTER OPERATING**
The LED turns green when the ED inverter is turned on. This LED normally turns on a few seconds after the AC line indicator LED and remains on during both utility and battery operation.
3. **ALM- ALARM STATUS INDICATOR**
This red LED turns on and a continuous audible alarm is sounded when the ED is overloaded or has failed. Should this occur, check the load level and correct any overload condition if present. Should the unit not be overloaded, call FALCON® support for further assistance.
4. **LOW BATT.- LOW BATTERY WARNING INDICATOR**
The red LED will turn on when the ED is configured with an optional external battery bank, operating in battery mode and the low battery level warning point has been reached. Typically one minute of battery run time remains after the LED turns on.
5. **OVERLOAD/ FULL LOAD/ 75% LOAD/ 50% LOAD-**
Adjacent to the red low battery LED is the green 50% load LED.
Adjacent to the green 50% load LED is the green 75% load LED.
Adjacent to the green 75% load LED is the yellow 100% load LED.
Adjacent to the yellow 100% LED is the red overload LED. All overload conditions must be corrected immediately.

TYPICAL ED3000 & ED4000 REAR PANEL LAYOUT

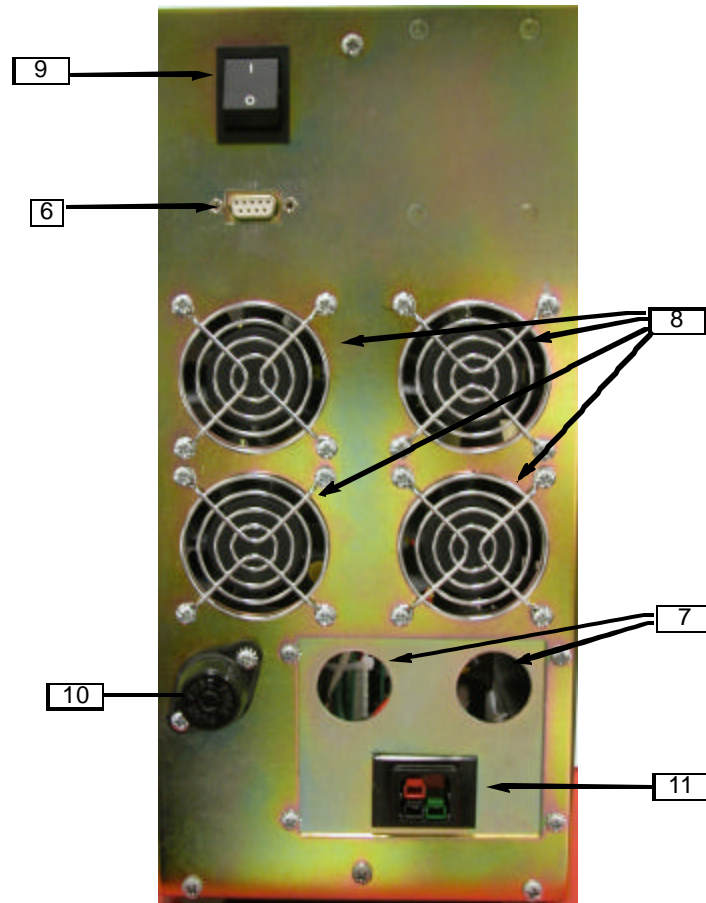

6. **DB-9F COMMUNICATIONS INTERFACE**
This connector gives access to the ED contact closure status interface. Please reference page 7 of this manual for details.
7. Hardwire conduit connector mounting holes for input and output wiring.
8. **COOLING FANS (4)**
Cooling fans draw cool air from the outside of the rear panel and exhaust it out through slots in the ED front panel. ALWAYS KEEP COOLING FAN AND FRONT PANEL VENTS CLEAR OF DEBRIS. DO NOT OPERATE THE ED IN AN ENCLOSED SPACE.
9. **MAIN POWER SWITCH**
To turn on this unit, toggle this switch to the on or (1) position. To turn off this unit, toggle this switch to the off or (0) position.
10. **INPUT FUSE**
Always replace this fuse with the same type and rating. The fuse is a Bussman, KTK-R-30, 30 Amp fuse.
11. **Battery Connector (72Vdc)**
This connector may be connected to an optional external battery bank, allowing the unit to be used as a UPS in addition to it's normal frequency conversion functions. The ED unit has been configured from the factory with an internal battery charger. This unit is field upgradable. Contact the factory for details.

CHAPTER 4

DB-9 COMMUNICATIONS INTERFACE

SIGNALS AND INTERFACING

The **FALCON**® ED unit is designed to be compatible with all sophisticated operating systems when they feature a Shutdown monitoring function. These signals are made available through a DB-9 subminiature, female connector at the rear of the unit. Interfacing cables are available. Below is a diagram of the 9-pin jack and its pin-out:

- 1 - **+12V SOURCE RETURN**
- 2 - **UTILITY INTERRUPT, Normally Open Contact**
- 3 - **UTILITY INTERRUPT, Normally Closed Contact**
- 4 - **COMMON, Contact Closures**
- 5 - **LOW BATTERY, Normally Open Contact**
- 6 - **AUTOMATIC SHUTOFF CIRCUIT (ASC)**
- 7 - **ASC RETURN**
- 8 - **+ 12VDC @ 30ma SOURCE**
- 9 - **- 12VDC @ 30ma SOURCE**

NOTES:

- 1. Contacts rated 2A @ 28VDC.
- 2. A +5 to +12VDC signal applied to pin 6 with respect to pin 7 for at least one millisecond when no utility power is present will cause the ED to shutdown. The current drawn is about 2ma @ 5VDC and 5ma @ 12VDC. The 12VDC source provided at pins 8 to 1 may be utilized for this function. Upon the return of utility power, restart is automatic.
- 3. NORMAL contact states are maintained with system power "ON" and the Inverter operational or with system power completely "OFF".

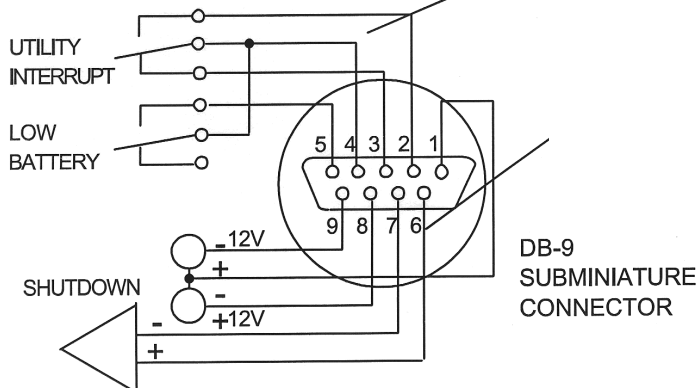

CHAPTER 5

OPERATION

The FALCON® ED unit is very simple to use.

1. Verify the unit is connected to the correct voltage power source.
2. Activate the power switch to the "ON" position.
3. The green AC LED illuminates.
4. The green INV LED illuminates.
5. For frequency conversion models, verify the output frequency is set to the desired frequency using a frequency meter. Disregard the following steps 6-11.
6. For models supplied with optional battery banks, leave the power switch "ON" and open the input circuit breaker at the utility panel, This will simulate a power loss & test battery operation.
7. The green AC LED will shut off.
8. An intermittent audible alarm will sound.

The system will continue to operate. If this were to continue long enough, the red LOW BATTERY light would illuminate, indicating that battery back-up time is ending and system shutdown is imminent. The intermittent alarm will become continuous at this point. The ED unit will automatically shut itself off to avoid excessive battery discharge. When power returns, normal operation of the UPS resumes without any operator adjustment.

The duration of actual battery back-up time and the low battery condition varies depending on the amount of load, charge on the battery, and condition of the battery. Refer to the ED SPECIFICATIONS for approximate hold-up times at 100% and 50% loads.

9. Reset the input circuit breaker and turn the power switch "OFF".
10. Turn off the devices you wish to plug into the ED. Plug them into the outlets located on the rear of the ED.
11. Activate the ED unit power switch to the "ON" position.
12. Turn "ON" each of your devices.
13. Some of the LOAD indicators may illuminate. The amount of load determines the actual number of indicators lit.
The bottom green L.E.D. signifies approximately 50% of load capacity. The second green L.E.D. represents approximately 75% of load capacity. If the yellow L.E.D. illuminates, full load has been achieved. If the red light illuminates, an OVERLOAD condition is present. If this situation continues for about 15 seconds, the unit will automatically shut off.
If the system overheats or the Inverter should fail, the unit automatically shuts off and sounds a continuous alarm and the red ALM light will illuminate.

To escape this condition, the problem must first be corrected then turn the ED power switch "OFF", then back "ON".

For models supplied with batteries it is recommended that you leave the ED unit power switch "ON" at all times and switch your devices "OFF" individually. This will ensure that your batteries are always at a maximum charged state.

WARNING

The power switch acts as a system ON/OFF switch. When this switch is turned "OFF", power is lost to the entire unit including all outlets at the rear of the ED.

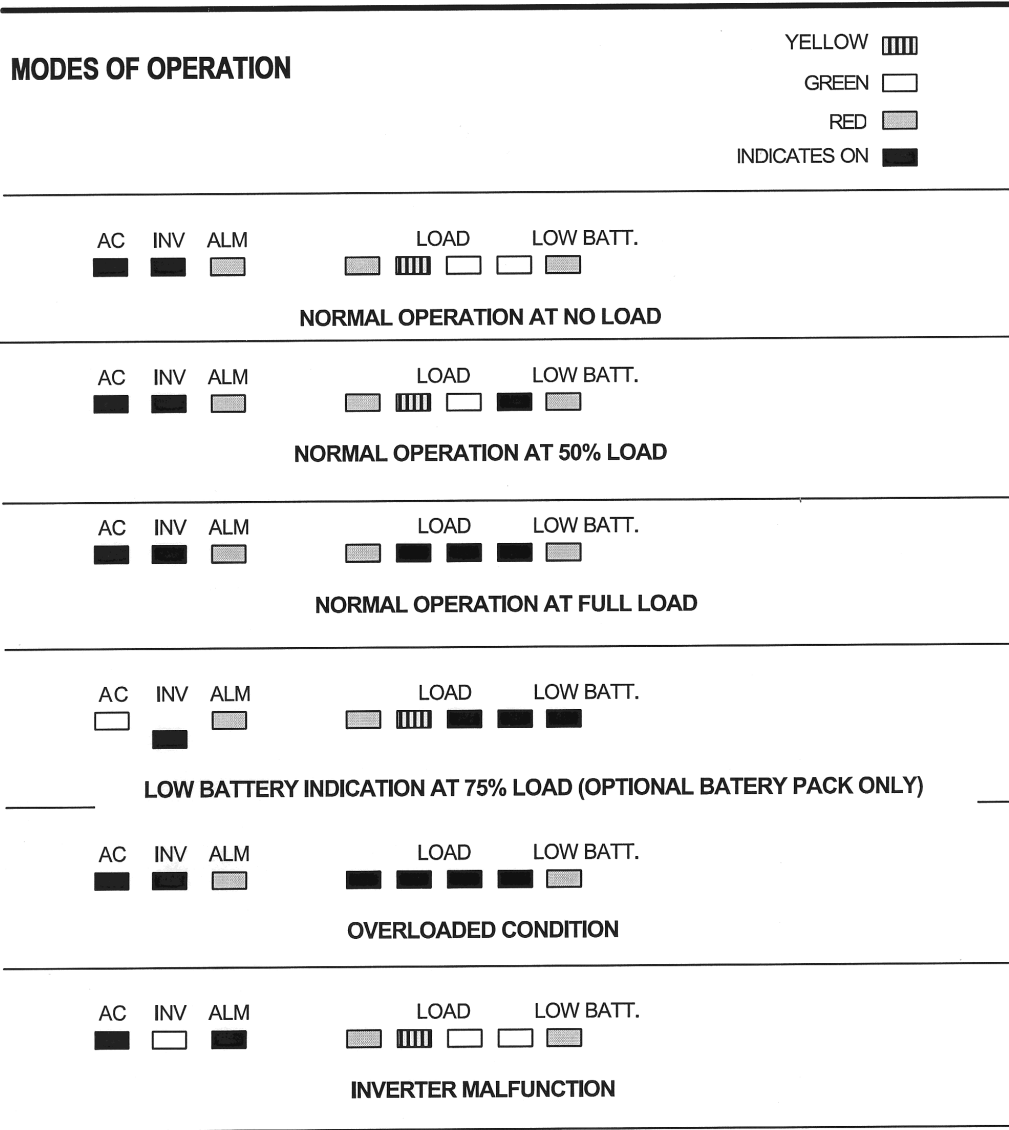

CHAPTER 6

Maintenance & Technical Support

1. **Care & Maintenance**

Falcon® ED Series are designed to be maintenance-free.

They can be cleaned with a damp cloth or non-abrasive cleanser, providing the ED is turned off and the input plug is disconnected from the utility source.

On a regular basis, check the vents to make sure they are kept free from accumulation of dust, dirt or lint.

2. **Battery Life vs. Temperature (Units supplied with batteries only)**

For full battery life, keep the ED close to an ambient temperature of 77°F.

The batteries should never be exposed to temperatures below 40°F and above 104°F

3. **Battery Replacement (Units supplied with batteries only)**

This unit contains sealed maintenance-free batteries (VRLA). When situated in a typical office environment, with the proper charging and limited cycling, these batteries can last many years. We recommend that the batteries be replaced every three years.

WARNING

Never attempt to service batteries. High voltage exists within the unit, which could cause electrical shock. **Servicing of batteries should be performed or supervised by personnel knowledgeable of batteries and the required precautions.** Keep unauthorized personnel away from batteries.

When replacing the ED batteries, use the same number and type of batteries.

NEVER

A. **NEVER** dispose of batteries in a fire, as batteries will explode.

B. **NEVER** dispose of used batteries or the UPS in the trash or landfill as it is against federal and state laws. **The ED and Batteries must be recycled.**

For battery recycling information, please contact our service department for the name and address of the nearest battery recycling facility.

C. **Spent batteries must be recycled in accordance with all Federal, State and local laws. To locate a recycling center near you contact the Falcon service department.**

CAUTION

A. Do not open or mutilate the battery or batteries. Released electrolyte is harmful to the skin and eyes. It may be toxic.

B. A battery can present a risk of electrical shock and high short circuit current. **REFER ALL BATTERY SERVICING OR REPLACEMENT TO A QUALIFIED SERVICE TECHNICIAN. UNTRAINED PERSONNEL SHOULD NEVER ATTEMPT BATTERY REPLACEMENT.**

The following precautions should be observed by a qualified technician when working with batteries.

1. Remove watches, rings, or other metal objects.
2. Use tools with insulated handles.
3. Wear rubber gloves and boots.
4. Do not lay tools or metal parts on top of batteries.

4. **Storing the ED unit**

Should you need to store the ED for a long period, if supplied with batteries, fully recharge the battery just prior to storage and recharge the battery every 6 months by plugging the ED into a power outlet and turning the unit on. It is recommended that the batteries charge for 24 hours after long-term storage.

5. **FCC**

This equipment generates and uses radio frequency energy and if not installed and used properly in strict accordance with the manufacturer's instructions, may cause interference to radio and television reception. All models covered in this manual have been tested and found to comply with the limits for a Class A computing device, in accordance with the specifications in FCC regulations, Part 15, Subpart J, which are designed to provide reasonable protection against such interference.

If this equipment does cause harmful interference to radio or television reception, which can be determined by turning the equipment off and on, the user is encouraged to try to correct the interference by one or more of the following measures:

- a. Reorient or relocate the receiving antenna.
- b. Increase the separation between the equipment and the receiver.
- c. Connect the equipment into an outlet on a circuit different from that to which the receiver is connected.
- d. Consult the dealer or an experienced radio/television technician for assistance.

6. **Technical Support**

Your FALCON® Electric ED Series is backed by one of the finest customer service teams assembled. Write, Call, Fax or Email should you require technical assistance or service.

FALCON ELECTRIC, INC.
5116 Azusa Canyon Road
Irwindale, CA. 91706
Voice 626.962.7770
Fax 626.962.7720
Service 800.842.6940
Email: service@falconups.com
WWW.FALCONUPS.COM

Should service be desired, you must first obtain a Return Material Authorization number (RMA) and return shipping instructions from our customer service department. Please have your ED model, serial numbers and date of purchase on hand prior to the call. This information is located on the identification label on the rear panel of the unit. This information is essential in retrieving your unit's historical records.

The RMA number issued must appear on the outside of the shipping carton. The original shipping container must be used when returning any ED Series product. Falcon® Electric will not assume any responsibility for shipping damage. In the event of shipping damage, you will be charged for repairs due to the damage.

All units must be returned prepaid. The address and shipping instructions will be given to you at the time the RMA is issued.

7. **Requesting Technical Information or Support.**

You may request technical information or support by Email or telephone.

Please send your technical or support questions by Email to:

SUPPORT@FALCONUPS.COM

You may contact a FALCON support engineer directly by calling the FALCON support line between 9:00 am and 4:00 pm PST.

800-842-6940

8. **FALCON Web Support**

Product data sheets, specification and owner's guides are available in Adobe .PDF format on our corporate website.

WWW.FALCONUPS.COM



Uninterruptible Power Systems & Power Conversion Products

ED Series™ UVS PLUS® 1kVA to 4kVA Voltage & Frequency Converters

- True Double Conversion Design
- Precision Output Voltage & Frequency
- Pure Sinewave Output
- Wide Input Frequency Range
- 50, 60 & 400Hz Frequency Conversion
- Voltage Conversion Models Available
- Eliminates Generator Frequency & Voltage Drift
- Superior Brownout, Surge and Transient Protection
- Battery Backed Up Models Available



Technology Breakthrough

Falcon® Electric's ED Series™ UVS Plus® is more than an international voltage/frequency converter, voltage regulator or line conditioner. Its unique features will significantly improve your equipment's reliability, virtually eliminating power-related downtime and dramatically increasing productivity. Its small size and lightweight construction makes it ideal for OEM and integrated applications.

Unique Frequency Converter & UPS Capability

The ED Series provides unique flexibility in a small footprint. The ED Series can be factory configured as a pure frequency converter accepting a 50, 60 & 400Hz input and yielding a fixed 50 or 60Hz output. It can also supply a 400Hz, 120V output if properly derated. The ED can be configured as an international converter, making it an ideal solution for those tough applications requiring both voltage and frequency conversions. A battery system may be added to most models, turning it into a true Regenerative On-line UPS.

Superior Voltage/Frequency Regulation & Extended Brownout Protection

Since the ED Series is a solid-state generator, it prevents daily power disturbances from reaching your equipment. Constant voltage transformers, line conditioners and other devices are not designed to prevent damage from these problems.

The ED continually regenerates new, clean AC power in pure sinewave form for superior protection. Even with wide input variations in voltage and frequency, the ED Series UVS Plus's output steadfastly remains at its designed voltage and frequency. It also allows your system to continuously operate during extended brownouts to 88 VAC.

Enhanced Surge Start-up Capability

Falcon Electric's ED Series is designed to start loads that exhibit up to 1000% inrush current when started from utility. This gives the ED the ability to start tough loads such as motors, multiple computers or incandescent lighting.

Converts Generator Output Into Computer-Grade Power

Due to its Regenerative On-line design, the ED Series regenerates new, clean computer-grade power with tightly regulated voltage and frequency, independent of generator voltage and frequency drift.

Ideal for applications such as:

- Military & Aerospace
- Aircraft Frequency Conversion
- Off Shore Platforms
- Shipboard Systems
- Robotics
- Automated Manufacturing
- Test Equipment Benches
- Precision Motor Speed Application
- Mobile Office/Labs
- Communications/Microwave

ED Series Model -A Frequency Converter (120V Input/Output)

Model Number	ED-1000-A	ED-1500-A	ED-2000-A	ED-3000-A	ED-4000-A
Nominal VA	1000	1500	2000	3000	4000

Electrical Input

AC Voltage, +10% -20%	120V	120V	120V	120V	120V
Current-Amps	10.4	15.6	20.8	29	39
Frequency Range	47 – 450	47 - 450	47 - 450	47 - 450	47 - 450

Electrical Output

AC Voltage, ± 3%	120V	120V	120V	120V	120V
Watts @ 50 or 60 Hz	700	1050	1400	2100	2800
Watts @ 400 Hz (-400 option)	595	892	1190	1785	2380
Current-Amps @ 50/60 Hz	8.3	12.5	16.7	25	33
Current-Amps @ 400Hz	7.1	10.6	14.2	21.3	28
50/60 Hz Non – Linear Repetitive Peak (Amps)	20	30	40	60	80
400 Hz Non – Linear Repetitive Peak (Amps)	14.2	21.3	28.3	42.5	56
Total Harmonic Distortion	< 3% @ 100% Linear Load, < 5% @ 100% Non – Linear Load				
Overload	200% for 0.5 Seconds, 120% for 30 Seconds				
Dynamic Response	± 5% RMS for 100% Step Load Change, 1ms Recovery Time				
Output Protection	Short Circuit and Overload				

Electrical Connections

Input	6' Cord with 5-15P	8' Cord with 5-20P	8' Cord with L5-30P	Hardwired	Hardwired
Output	(4) 5-15R	(4) 5-15R	(4) 5-15R	Hardwired	Hardwired

Environmental

Operating Temperature	0° C to 35° C (32° F to 95° F)				
Humidity	10% to 95% Non – Condensing				
Altitude	7,000 Feet				
Cooling	Low Velocity Forced Air Fans				
Audible Noise @ 1.5 Meters	49dBA		54dBA		

Controls and Indicators

Sequenced LEDs	Load Level				
Single LED	Utility Present, Summary Alarm, Inverter On				
Audible Alarms	Utility Interrupt, Inverter Failure, Overload				
Communications	Dry Contact Closures on Utility Loss via 9 Pin "D" Connector				

Mechanical

Dimensions H x W x D inches (mm)	13.5 x 6.25 x 19.4		(342.9 x 158.8 x 492.8)		
Weight lb. (kg)	25 (11.3)	38 (17.2)	38 (17.2)	50 (22.7)	50 (22.7)

Specify input/output frequency, 50/60 or 400Hz (any combination).
Standard models shown. Custom configurations available; Consult Factory.

Note: For ED3000-A and ED4000-A models add a -400 to the end of the model number for a 400Hz output